

INSTRUCTIONS AND PARTS MANUAL

CW-7 CIRCLE WELDER

Please record your equipment identification information below for future reference. This information can be found on your machine nameplate.

Model Number _____

Serial Number _____

Date of Purchase _____

Whenever you request replacement parts or information on this equipment, always supply the information you have recorded above.

LIT-CW-7-IPM-0614

Bug-O Systems is guided by honesty, integrity and ethics in service to our customers and in all we do.



BUG-O SYSTEMS

A DIVISION OF WELD TOOLING CORPORATION



280 TECHNOLOGY DRIVE CANONSBURG, PENNSYLVANIA 15317-9564 USA
PHONE: 412-331-1776 <http://www.bugo.com> FAX: 412-331-0383

SAFETY

PROTECT YOURSELF AND OTHERS FROM SERIOUS INJURY OR DEATH. KEEP CHILDREN AWAY. BE SURE THAT ALL INSTALLATION, OPERATION, MAINTENANCE AND REPAIR PROCEDURES ARE PERFORMED ONLY BY QUALIFIED INDIVIDUALS.



ELECTRIC SHOCK can kill.

- 1) The equipment is not waterproof. Using the unit in a wet environment may result in serious injury. Do not touch equipment when wet or standing in a wet location.
- 2) The unused connectors have power on them. Always keep the unused connectors covered with the supplied protective panels. Operation of the machine without the protective panels may result in injury.
- 3) Never open the equipment without first unplugging the power cord or serious injury may result.
- 4) Verify the customer-supplied power connections are made in accordance with all applicable local and national electrical safety codes. If none exist, use International Electric Code (IEC) 950.
- 5) Never remove or bypass the equipment power cord ground. Verify the equipment is grounded in accordance with all applicable local and national electrical safety codes. If none exist, use International Electric Code (IEC) 950.

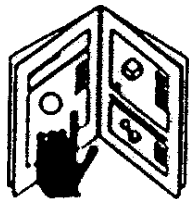

READ INSTRUCTIONS.

Read the instruction manual before installing and using the equipment.



EQUIPMENT DAMAGE POSSIBLE.

- 1) Do not plug in the power cord with out first verifying the equipment is OFF and the cord input voltage is the same as required by the machine or serious damage may result.
- 2) Always verify both the pinion and wheels are fully engaged before applying power or equipment damage may occur.
- 3) Do not leave the equipment unattended.
- 4) Remove from the worksite and store in a safe location when not in use.



FALLING EQUIPMENT can cause serious personal injury and equipment damage.

Faulty or careless user installation is possible. As a result, never stand or walk underneath equipment.



MOVING PARTS can cause serious injury.

- 1) Never try to stop the pinion from moving except by removing power or by using the STOP control.
- 2) Do not remove any protective panels, covers or guards and operate equipment.

HIGH FREQUENCY WARNINGS

SPECIAL PRECAUTIONS ARE REQUIRED WHEN USING PLASMA, TIG OR ANY WELDING PROCESS THAT USES HIGH FREQUENCY TO STRIKE AN ARC.



WARNING: HIGH FREQUENCY CAN EFFECT MACHINE OPERATION AND THEREFORE, WELD QUALITY.

Read the precautions below before installing and using the equipment.

PRECAUTIONS:

- 1) Some plasma or welding cables are strong sources of high frequency interference. NEVER lay a plasma or welding cable across the controls of the machine.
- 2) Always physically separate the plasma or welding cable leads from the machine cables. For example, the plasma or welding cable leads should NEVER be bundled with a pendant cable or the machine power cord. Maximize the separation between any machine cables and the plasma or welding cables.
- 3) Strictly follow the grounding procedures specified for the plasma or welding unit. NOTE: Some plasma and welding units produce exceptionally large amounts of high frequency noise. They may require a grounding rod be driven into the earth within six feet (2 meters) of the plasma or welding unit to become compatible with an automatic cutting or welding process.
- 4) If the high frequency is produced using a spark gap, adjust the points so the gap is as small as possible. The larger the gap, the higher the voltage and the higher the interference.
- 5) Some plasma or welding units will inject high frequency interference into the AC power line. Use separate power line branches whenever possible to power the plasma or welding source and the machine. Do not plug them into the same outlet box.
- 6) High frequency noise may enter the machine through the plasma or welding supply remote contactor leads. Some plasma and welding sources can produce noise spikes of up to several thousand volts. These sources are not compatible with automated cutting and welding equipment. It is recommended that the remote contactor leads on these plasma or welding sources not be connected to the machine. An alternate solution is to purchase a separate remote contactor isolation box.

CW-7 CIRCLE WELDER

INSTRUCTIONS AND PARTS MANUAL

TABLE OF CONTENTS

PAGE

5.....	Introduction / Features / Setup and Operation
7.....	CWO-3332 Wire Feeder Controls
8.....	CWO-6210 Rotation Controls
9.....	Technical Data / Dimensions
10.....	CWO-1700 CW-7 Circle Welder / Exploded View
11.....	CWO-1700 CW-7 Circle Welder / Parts List
12.....	CW-7 Circle Welder / Wiring Diagram / Electrical Component Chart
13.....	CWO-3495 CW-7 Collector / Exploded View / Parts List
14.....	CWO-3139 Universal Power Cable / Exploded View / Parts List
14.....	CWO-3139-M Miller Power Cable/ Exploded View / Parts List
15.....	CWO-1665 CW-7 Racking System / Exploded View / Parts List
15.....	CWO-1690 Horizontal Racker / Exploded View / Parts List
16.....	CWO-2005 Wire Feeder Guard / Exploded View / Parts List
17.....	CWO-3027 Meter Kit Assembly / Exploded View / Parts List
17.....	CWO-3027 Meter Kit Assembly / Wiring Diagram
18.....	CWO-3496 Shaft Assembly / Exploded View / Parts List
18.....	CWO-3227 Cam Shaft & Spacer Assembly / Exploded View / Parts List
19.....	CWO-3205-11 7" Cam Assembly / Exploded View / Parts List
19.....	CWO-3498 5" Wire Reel Mount Assembly / Exploded View / Parts List
20.....	CWO-3063 Large Brush Holder and Support / Exploded View / Parts List
20.....	CWO-3194 Housing Assembly / Exploded View / Parts List
20.....	CWO-3361 P.M. Motor Assembly / Exploded View / Parts List
21.....	CWO-3359 Transmission 5:1 Assembly / Exploded View / Parts List
21.....	CWE-1530 Small Brush Holder Assembly / Exploded View / Parts List
21.....	CWO-3461 Small Retainer Block Assembly / Detail View
22.....	CWO-3332 GMA Wire Feeder Control / Exploded View / Parts List
23.....	CWO-3332 GMA Wire Feeder Control / Wiring Diagram / Electrical Component Chart
24.....	CWO-6210 Rotation Control / Exploded View / Parts List
25.....	CWO-6210 Rotation Control / Wiring Diagram / Electrical Component Chart
26.....	CW-7 Gun Assemblies (MIG-FLUX CORED)
27.....	CW-7 Gun Assemblies (SUB ARC)
28.....	CWO-3690- _ K231 Subarc Gun Assembly / Exploded View / Parts List
28.....	CW-7 Drive Roll Kits
29.....	CWO-3700- _ Subarc Gun Assembly / Exploded View / Parts List
29.....	CWO-3490 CW-7 Flux Hopper Assembly / Exploded View / Parts List
30.....	#5 Gun & Cable Assembly / Exploded View / Parts List
31.....	3- Jaw Expandable Chucks
32.....	Optional Motorized Racking Equipment / CWO-1665-MV / Exploded View / Parts List
33.....	Optional Motorized Racking Equipment / CWO-1690-MH / Exploded View / Parts List
34.....	Optional Motorized Racking Equipment / CWP-3350 / Exploded View / Parts List
35.....	Optional Motorized Racking Equipment / CWP-3351 / Exploded View / Parts List
36.....	Optional Motorized Racking Equipment / PRS-1100 / Exploded View / Wiring Diagram
37.....	Optional Motorized Racking Equipment / PRS-1100 / Parts List
38.....	Optional Motorized Racking Equipment / CWP-3363 / Exploded View / Parts List
38.....	Optional Motorized Racking Equipment / PRS-1075 / Exploded View / Parts List
39.....	Preventive Maintenance / CW-7 Circle Welder
42.....	Warranty

INTRODUCTION

The CW-7 Circle Welder is designed for welding of nozzles into vessels or domed heads utilizing SUB-ARC, MIG or FLUX CORED PROCESS, with gas shielding. The CW-7 mounts on a 3-Jaw Chuck welding diameter 6" to 50" O.D.

Features:

- Amperage & wire speed control
- Wire feeder with one set of drive rolls
- 1/12 HP P.M. motor and rotational speed control
- 500 AMP gun & cable assembly
- Gas shielding kit with 120 VAC solenoid valve
- 5/8" (16 mm) gas cup
- Burn back control
- 50 ft. (15 m) power cable
- 50 ft. (15 m) gas shielding hose
- 50 ft. (15 m) weld cable
- Quick disconnects for all cables
- Weld contact switch
- Cold wire inch switch
- Wire direction switch
- Pre and post flow controls
- Wire reel adaptor for 60 lb. (27 kg) spools
- Adjustable vertical and horizontal torch positioning system
- Rise and fall cam assembly with 7" (178 mm) of travel
- Brushes and collector rings for welding current, rated at 500 AMPS 100% duty cycle
- Brushes and collector rings for all controls, eliminates cable and hose wrap

SETUP AND OPERATION:

POWER SOURCE:

Use only constant voltage type power sources with this circle welder machine. If using a multiple process power source, be sure that it is set for constant voltage output as per the instructions in the manual for the power source. Set the power source polarity switch or properly connect the electrodes and work leads for the correct electrode polarity.

GUNS AND CABLES:

All circle welders come equipped with a gun and cable assembly. It is our recommendation that at least once a week the liner be taken out of the cable and soaked overnight in a solvent solution. To keep the wire moving it is also recommended that a felt clip be saturated with a product like Ferro Slick and fed through the incoming tube of the wire feeder at least once a day.

SETUP AND OPERATION CONTINUED:

ADDITIONAL CABLES:

The circle welders are supplied with the following cables:

1. CWO-3139 50' (15 m) power cable that connects the power source to the cable connector on the top gear of the machine.
2. CWO-3040 50' (15 m) weld cable that connects the lead coming out of the top of the machine using the quick connect connector to your power supply.
3. CWO-9406 50' (15 m) gas shielding hose that connects the gas fitting on the top of the shaft to your shielding gas supply.

WIRE SPEED AND VOLTAGE ADJUSTMENT:

The wire speed control on the front of the CWO-3332 Wire Feed Control box has a dial that is calibrated directly in inches per minute. Set the voltage using the control on the power source.

RISE AND FALL OF THE CAM:

All circle welders are equipped with a rise and fall cam assembly. The cam assembly must be aligned before any other settings can be made. To align the cam rotate the machine so the horizontal rack is parallel to the pipe, then adjust the gun holder so it is perpendicular to the horizontal rack. Position torch tip to top dead center of joint. Loosen the set screws in the brass block on the cam, and rotate the cam to the vertical position as shown. Refasten set screws.

CAM SETTING:

The cam setting is equal to distance "B" subtracted from distance "A".

Example:

Let A=3 and B=2

$3-2=1$

The cam setting is 1.

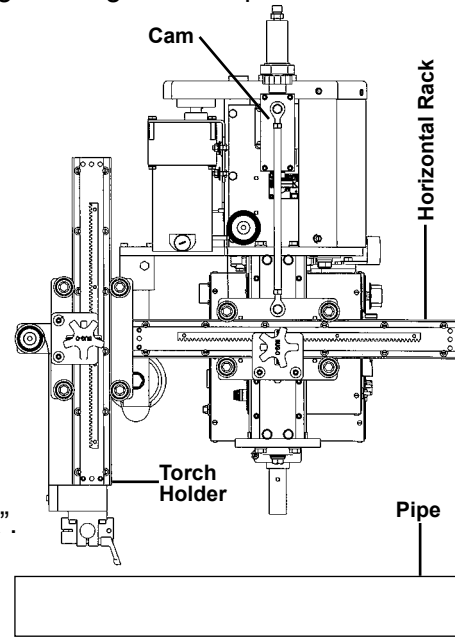
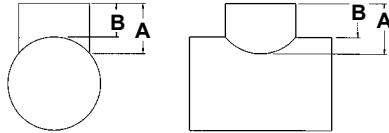

WHEEL ADJUSTMENT:

The CW-7 Racking System CWO-1665 and the Large Vertical Racker CWO-1690 are equipped with adjustable wheels. Always check these components for proper wheel adjustment before using the machine. The wheels need adjustment if you can cock or wiggle the components out of alignment. The wheels should be snug but not prohibit movement along the path of travel. The wheels with the hex stand offs are adjustable. To adjust the wheels, loosen the hex bolt (A) until the adjustable bushing (B) can be rotated. Correct the wheel alignment by rotating the adjustable bushing (B). Once adjusted, hold the adjustable bushing (B) while tightening the hex bolt (A). Recheck alignment.

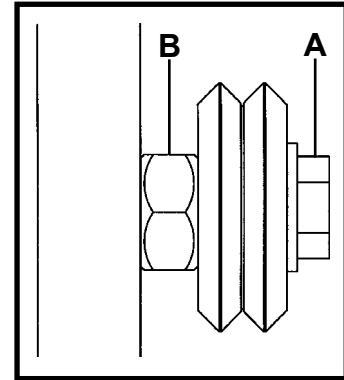

MACHINE CONTROLS:

Operational parameters can be set using the two control boxes. Please refer to the sections in this manual entitled CWO-3332 Wire Feeder Control for descriptions of the various welding parameters that are available, as well as CWO-6210 Rotation Control for descriptions of the various speed and directional capabilities.

MAKING A WELD:

1. Position the gun to start position using the CWO-1665 Racking System.
2. Connect the ground cable to the workpiece. The ground cable must make good electrical contact with the work.
3. Position the electrode in the joint. The end of the electrode may be lightly touching the work.
4. With manual/auto switch in the "OFF" position, set rotation direction and speed.
5. Weld process and rotation are both started by throwing the manual/auto switch to auto.
6. Weld process and rotation are stopped by throwing the manual/auto switch to "OFF".

WARNING: When using an open arc process, it is necessary to use correct eye head and body protection.

CWO-3332 WIRE FEEDER CONTROLS

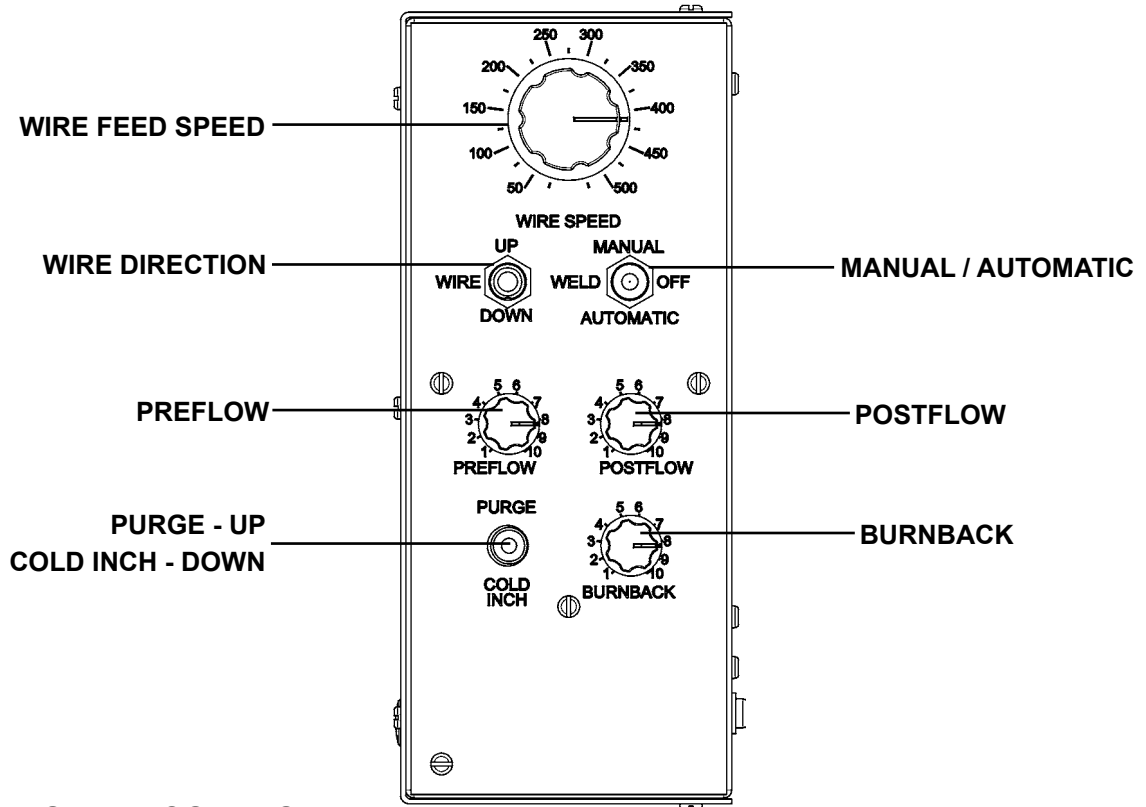

WIRE FEED SPEED CONTROL:

This control sets the feed speed of the wire feeder. Turn the knob to the left for slower speeds and to the right for higher speeds. The control is calibrated. The nameplate shows the wire speed for the given setting of the control.

WIRE DIRECTION:

Controls the direction the wire is being fed thru the feeder. **Up** to return wire to the spool. **Down** to feed the wire to the gun.

MANUAL / AUTOMATIC:

The manual position allows the operator to rotate the machine without welding to check the wire placement as well as the cam setting. The auto side will start the entire weld operation based on the operators settings, including machine rotation.

PREFLOW CONTROL:

This control, provides flow of shielding gas to the work before the arc is established. The gas solenoid valve is energized immediately when the gun trigger is closed, but the time delay before the wire feeder is energized is adjustable from 0 to 1.5 seconds. Turn the knob to the left for shorter delays and to the right for longer delays.

POSTFLOW CONTROL:

This control provides flow of shielding gas to the work after welding has stopped. Delay for the gas solenoid valve shutoff is adjustable from .5 to 4.5 seconds. Turn the knob to the left for shorter delays and to the right for longer delays.

PURGE - UP / COLD INCH - DOWN SWITCH:

This control provides control of some wire feeder functions without energizing the welding power source. The momentary up position energizes the gas solenoid but not the wire feeder or welding power source. The momentary down position energizes the wire feeder but not the gas solenoid or the welding power source.

BURNBACK CONTROL:

This control provides a precise time delay that allows the wire to be burned off at the end of the weld. This is useful for those applications where higher speed, fine wire feeding is used and there is a tendency for the electrode to overrun at the end of the weld and cause "sticking" in the crater. The delay is adjustable for optimum burnback depending on wire size, process, procedure, etc.

CWO-6210 ROTATION CONTROLS

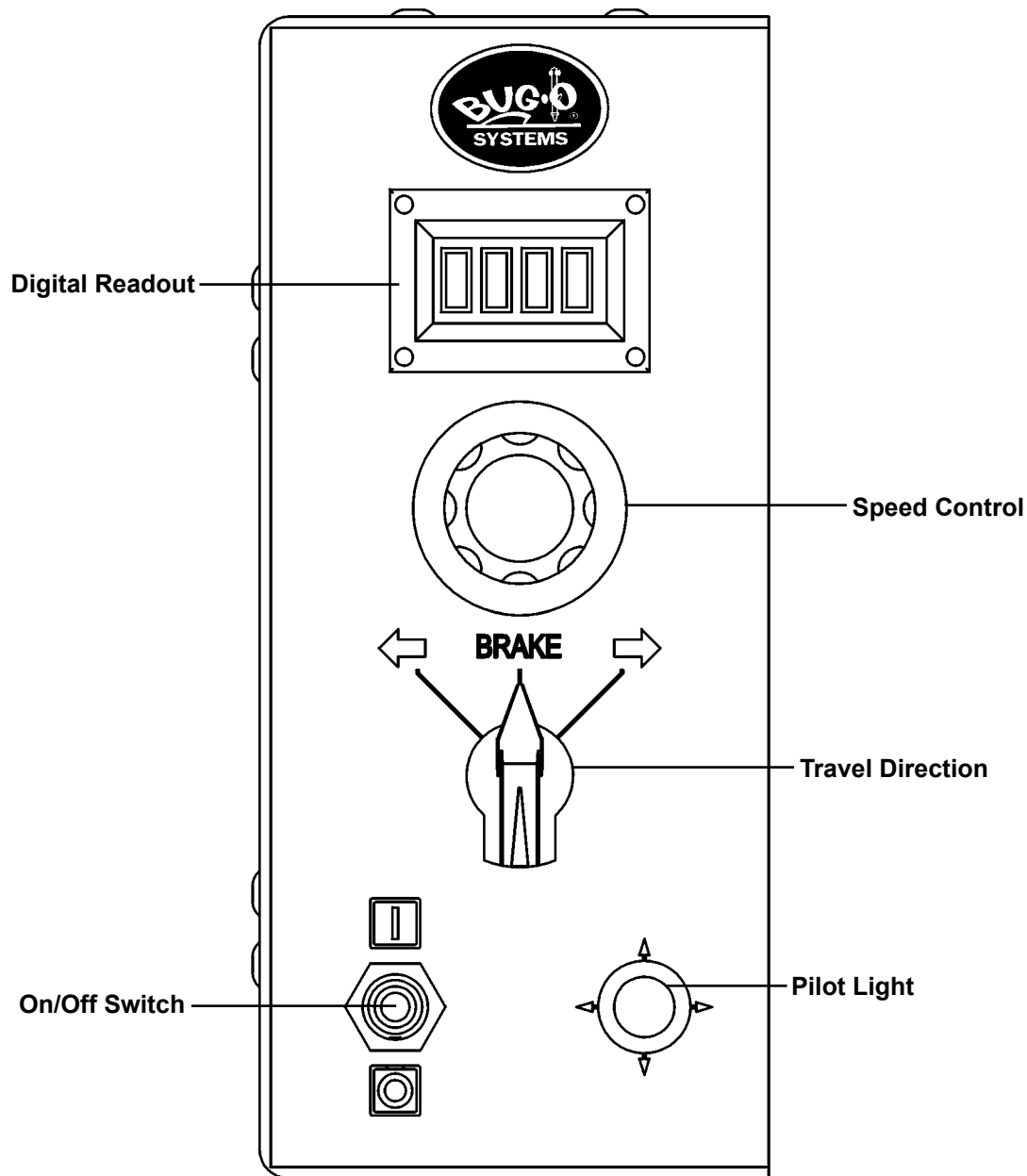

DIGITAL READOUT:

Displays reference number only.

SPEED CONTROL:

Controls the speed in which the machine travels. The depicted lines 0 to 100 should not be construed as inches per minute of travel. They should be considered as reference points only.

TRAVEL DIRECTION:

Controls the direction in which the machine will travel. Select forward for clockwise rotation, brake for stop, and reverse for counterclockwise rotation.

ON/OFF SWITCH:

The on/off switch enables/disables power to the rotation control box.

PILOT LIGHT:

The pilot light indicates whether the machine is on/off as dictated by the on/off switch.

TECHNICAL DATA:

Amperage:	0-500 amps
Input Voltage:	115 VAC
Voltage:	0-50 VAC
Wire Sizes:	.035-3/32" (.8-2.4 mm)
Rotation Speed:	.2-2.2 rpm
Cam Range:	0"-7" (0-175 mm)
Welding Diameter:	6"-24" (150-600 mm)
Shielding Gas:	Solenoid Control
Height:	34" (864 mm)
Net Weight:	250 lbs. (113.6 kg)
Shipping Weight:	380 lbs. (173.0 kg)

DIMENSIONS:

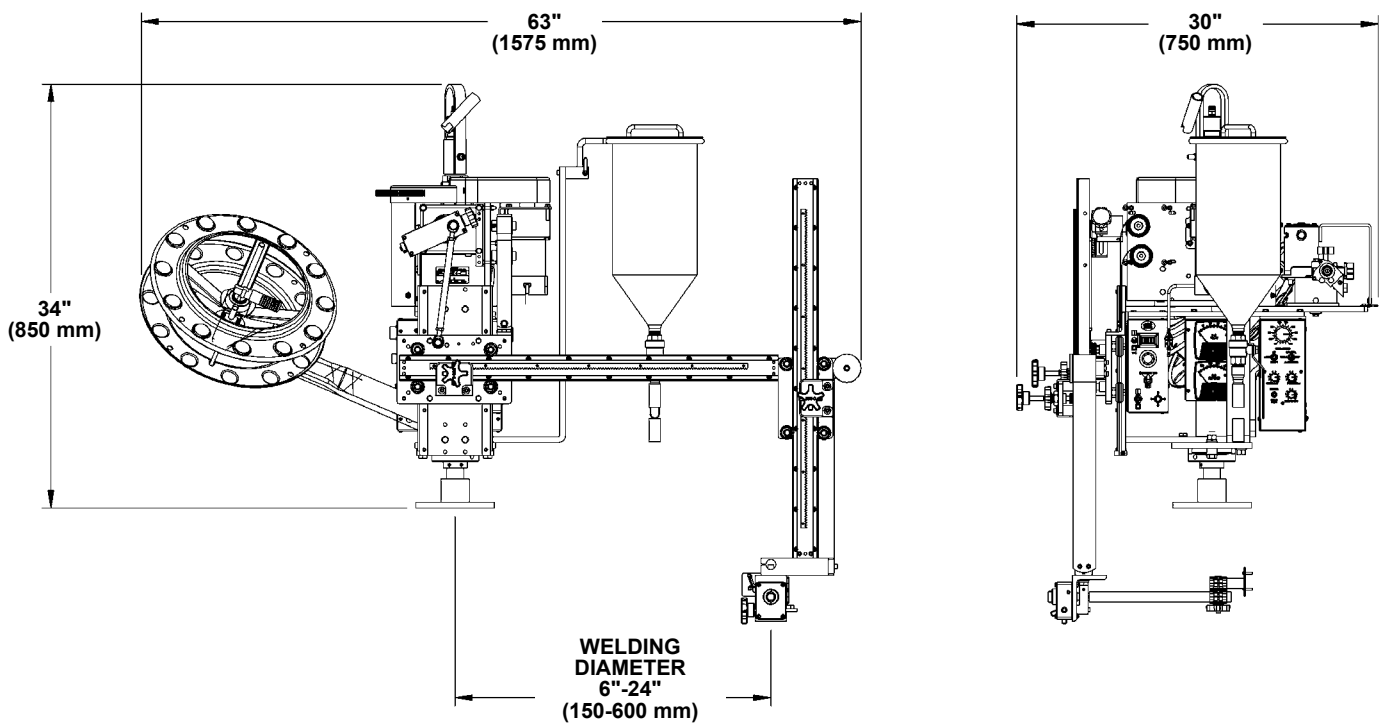

CWO-1700 CW-7 CIRCLE WELDER / EXPLODED VIEW

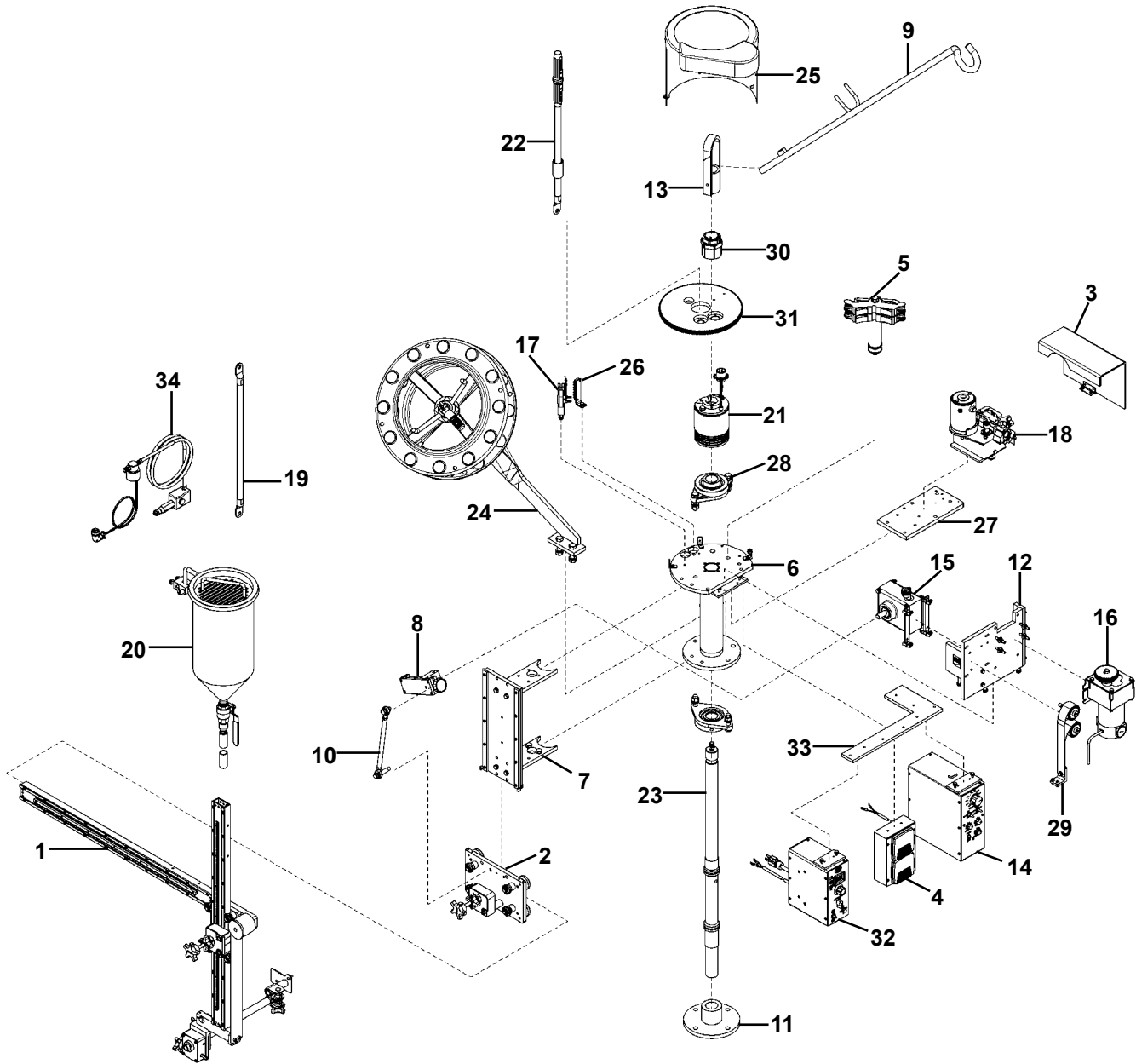

CWO-1700 CW-7 CIRCLE WELDER / PARTS LIST

<u>ITEM</u>	<u>QTY</u>	<u>PART NO.</u>	<u>DESCRIPTION</u>
1	1	CWO-1665	CW-7 Racking System
2	1	CWO-1690	Large Horizontal Racker
3	1	CWO-2005	Wire Feed Guard
4	1	CWO-3027	Meter Kit Assembly
5	1	CWO-3063	Brush Holder & Support Assy.
6	1	CWO-3194	CW-7 Housing Assy.
7	1	CWO-3204	Slide Bar Mounting Assy.
8	1	CWO-3205-11	7" Cam Assy.
9	1	CWO-3218	Cable Support Bar
10	1	CWO-3227	Camshaft & Bar Assy.
11	1	CWO-3287	Base Plate
12	1	CWO-3288	Motor & Transmission Plate Assy.
13	1	CWO-3312	Lifting Lug Assy.
14	1	CWO-3332	GMA Wire Feed Assy.
15	1	CWO-3359	Transmission SW 5:1 Assy.
16	1	CWO-3361	P.M. Motor Assy. #147
17	1	CWE-1530	Small Brush Retainer Assy.
18	1	CWO-3468	LN-7 Wire Feeder Assy.
19	1	CWE-1050-3/0	Weld Cable 3/0
*20	1	CWO-3490	Flux Hopper Assembly (Subarc models only)
21	1	CWO-3495	CW-7 Collector
22	1	CWO-3020-3/0	Weld Cable Inlet 3/0
23	1	CWO-3496	Shaft Assy., CW-7 AB, ABG
24	1	CWO-3498	Wire Reel Assy.
25	1	CWO-3499	CW-7 Guard Assy.
26	1	CWO-3955	Terminal Block Assy.
27	1	CWO-4088	Wire Feeder Mount Plate
28	2	CWO-4340	1-1/2" Flange Bearing
29	1	CWO-4900	33# Load Spring Assy.
30	1	CWO-5074	1-1/2" I.D. Trantorque
31	1	CWE-1048	10" Diameter Aluminum Gear
32	1	CWO-6210	Rotation Control Box
33	1	CWO-6416	Control Mount Plate
34	1	CWO-8057	Solenoid Adaptor Kit
35	1	CWO-3490	Flux Hopper

- Notes:**
1. See CWO-1700-WD for wiring and cable information.
 2. CWO-3332 is shown with CWO-3332-K kit installed.
 3. CWO-6210 is shown with CWO-6210-K kit installed.

* CWO-3490 Flux Hopper Assembly is installed on Subarc models only

CW-7 CIRCLE WELDER / WIRING DIAGRAM

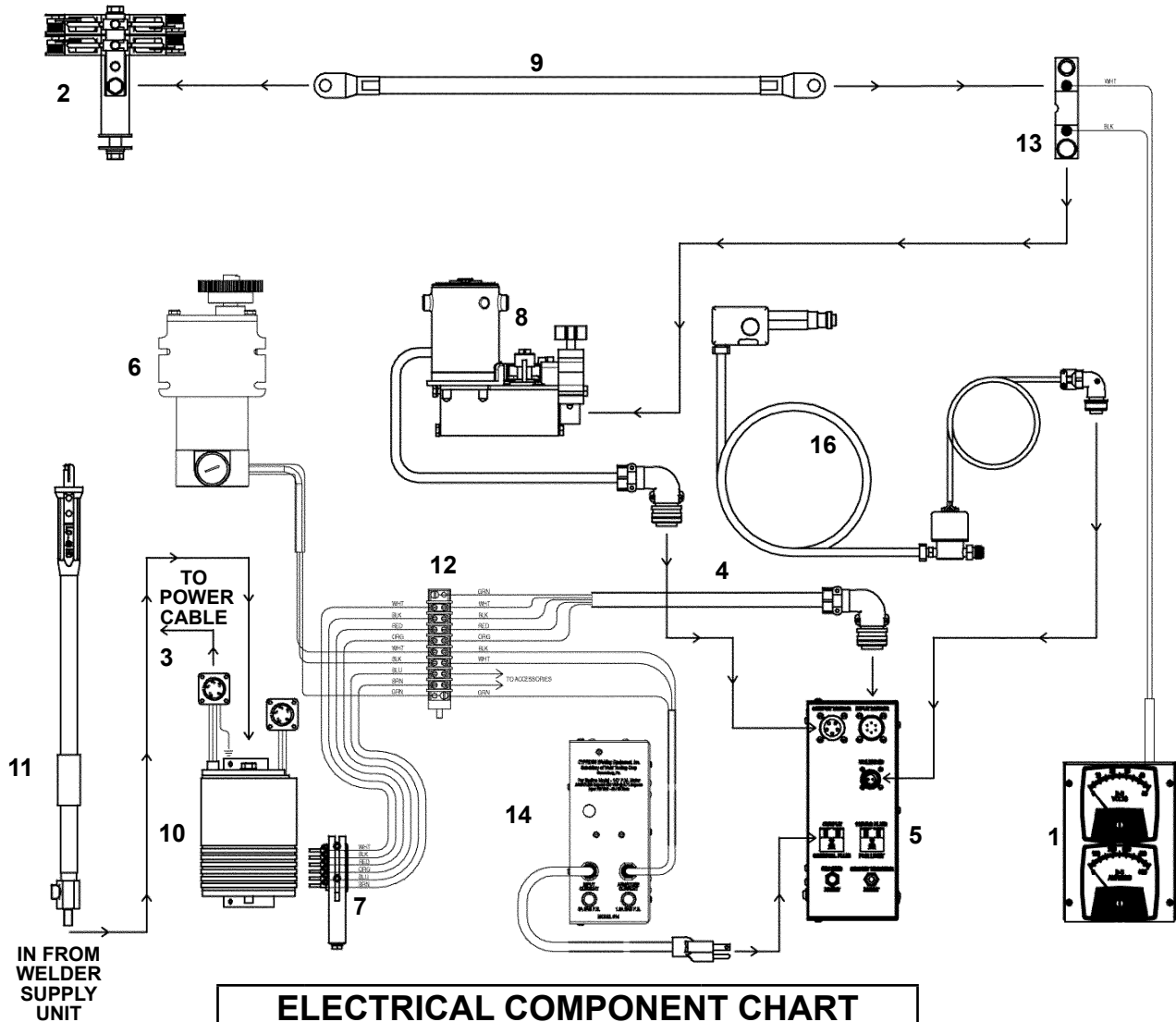

ELECTRICAL COMPONENT CHART		
ITEM	DESCRIPTION	PART NO.
1	Meter Kit Assembly	CWO-3027
2	Brush Holder & Support Assy.	CWO-3063
3	Power Cable	CWO-3139*
4	GMA Pigtail	CWO-3331
5	GMA Wire Feed Control	CWO-3332
6	P.M. Motor Assy.	CWO-3361
7	Small Brush Retainer Assy.	CWE-1530
8	LN-7 Wire Feeder Assy.	CWO-3468
9	Weld Cable 3/0	CWO-3478
10	CW-7 Collector	CWO-3495
11	Weld Cable Inlet 3/0	CWE-1050-3/0
12	CW-5 Terminal Block	CWO-3955
13	Shunt Bar 500-50	CWO-6008
14	Rotation Control Box	CWO-6210
15	Solenoid Adaptor Kit	CWO-8057

*CWO-3139 For Universal Welders

CWO-3139-M For Miller Welders.

CWO-3495 CW-7 COLLECTOR / EXPLODED VIEW / PARTS LIST

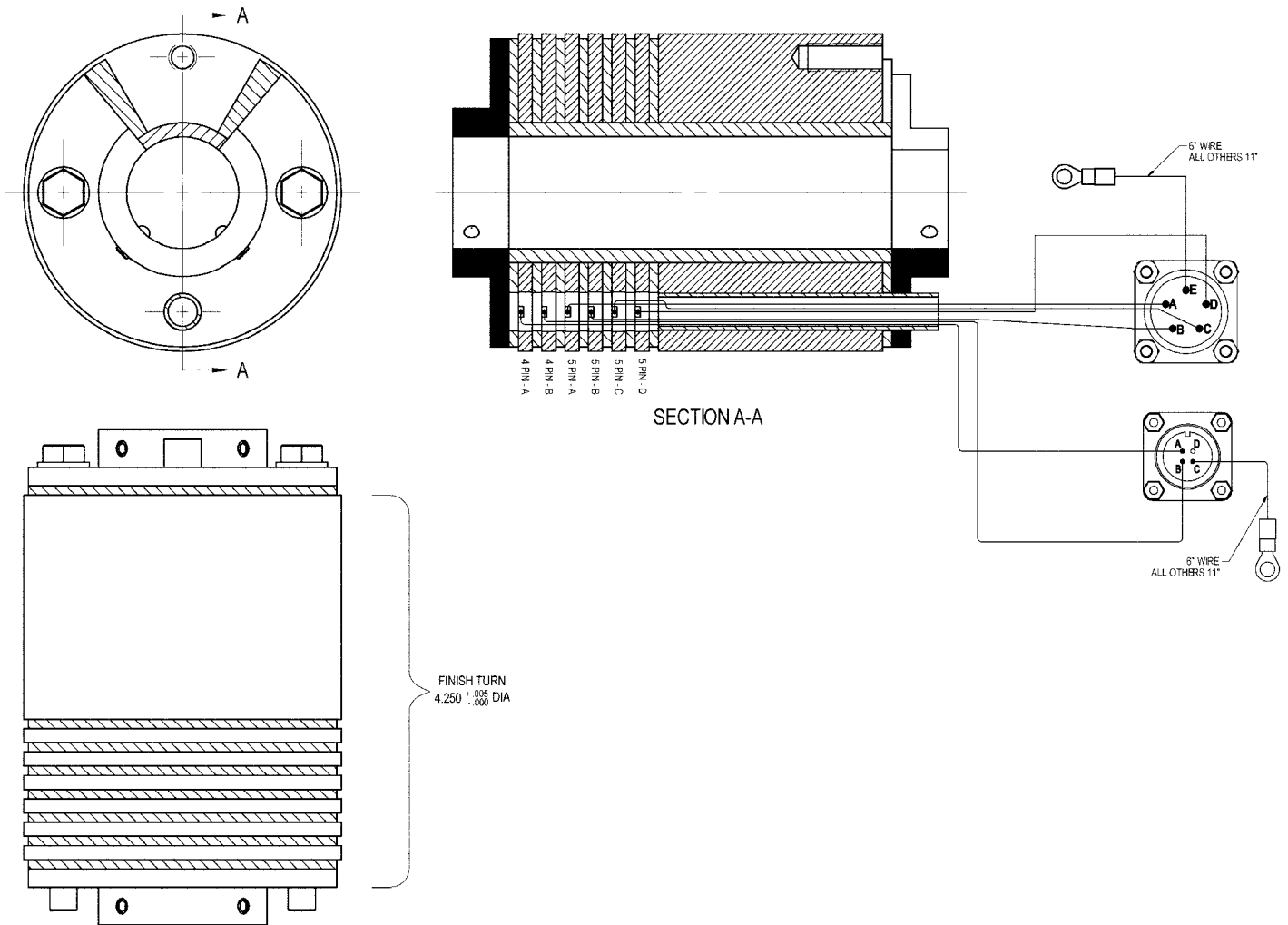

<u>ITEM</u>	<u>QTY</u>	<u>PART NO.</u>	<u>DESCRIPTION</u>
1	6	CWO-3127	Brass Ring 4.250" Dia x .188 Thk
2	1	CWO-5741	Brass Ring 4.250" Dia x 3.000 Thk
3	7	CWO-5744	Micarta Spacer
4	1	CWO-5747	Micarta Spacer w/Notch
5	1	CWO-5748	Micarta Sleeve .500" Dia x 3.750" Lg
6	2	CWO-5806	Micarta Sleeve .500" Dia x 5.375" Lg
7	1	CWO-5752	Micarta Sleeve 1.875" Dia x 4.50" Lg
8	1	CWO-5745	Top Plate CW-5 Collector
9	1	CWO-5746	Bottom Plate CW-5 Collector
10	1	CON WTE 0383	5 Pos Box Mounting Connector Plug
11	2	TERM-5494	#8 Red Ring Connector
12	4	FAS-0215	6-32 X 1/2" Rnd Hd Scr
13	4	FAS-0455	1/4"-20 X 1/2" Soc Hd Set Scr
14	4	FAS-1310	6-32 Hex Nut
15	2	FAS-0393	Hex Hd Cap Scr 3/8-16 x 6"
16	2	WAS-0260	3/8" SAE Washer
17	4	FAS-0204	Rnd Hd Slot Scr 4-40 x 3/8 Zinc
18	4	FAS-1305	Hex Nut 4-40
19	1	BUG-1034	Panel Connector, 4-T, M

CWO-3139 UNIVERSAL POWER CABLE / EXPLODED VIEW / PARTS LIST

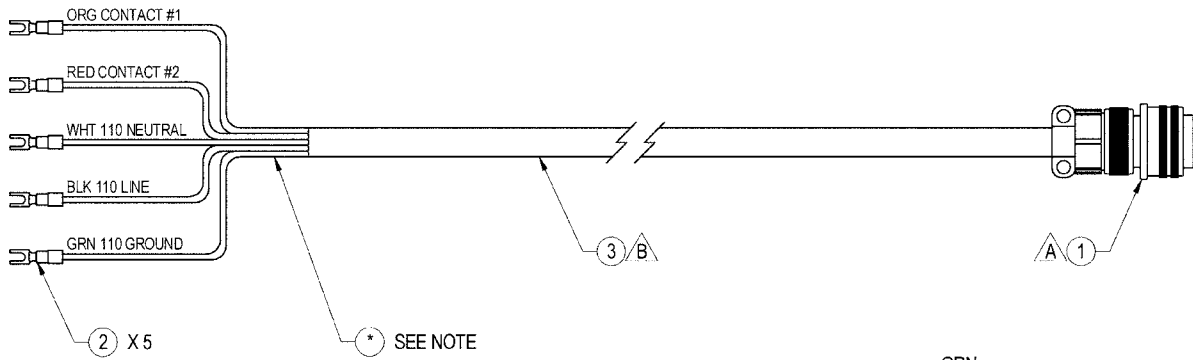

PARTS LIST

ITEM	PART #	DESCRIPTION	QTY
1	CON-PS05F	PLUG, STRAIGHT, 5 PIN, FEMALE	1
2	TERM WTE 0602	#6 BLUE FORK	5
3	900-4-014	16 AWG 6 COND. SO BLACK	600"

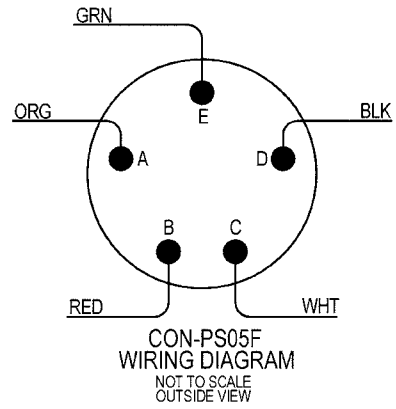

CWO-3139-M MILLER POWER CABLE / EXPLODED VIEW / PARTS LIST

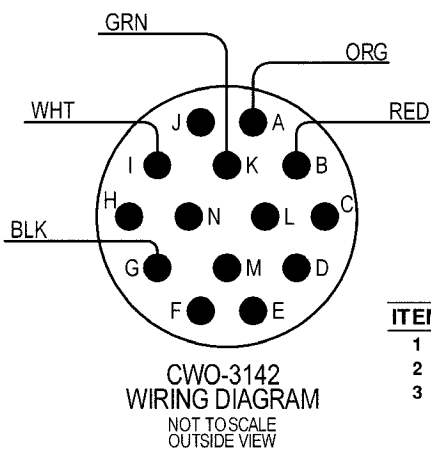
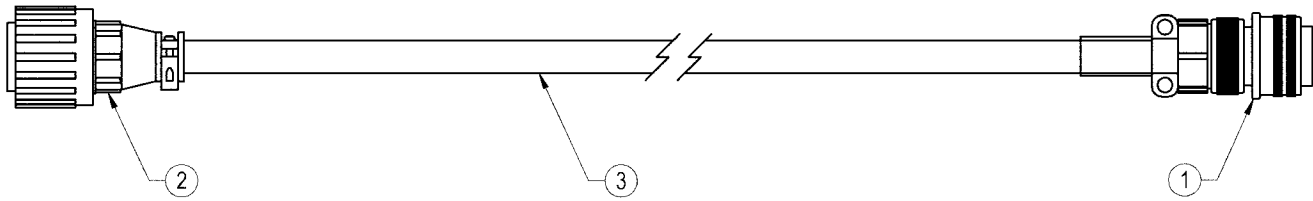

PARTS LIST

ITEM	PART #	DESCRIPTION	QTY
1	CON-PS05F	PLUG, STRAIGHT, 5 PIN, FEMALE	1
2	CWO-3142	HOUSING PLUG 14 PIN	1
3	900-4-014	6 COND. 16 AWG SO BLACK	600"

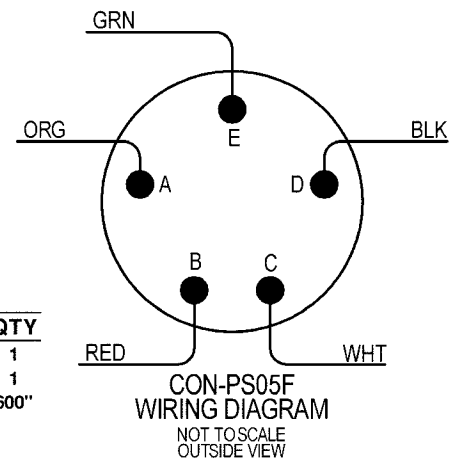

CWO-1665 CW-7 RACKING SYSTEM / EXPLODED VIEW / PARTS LIST

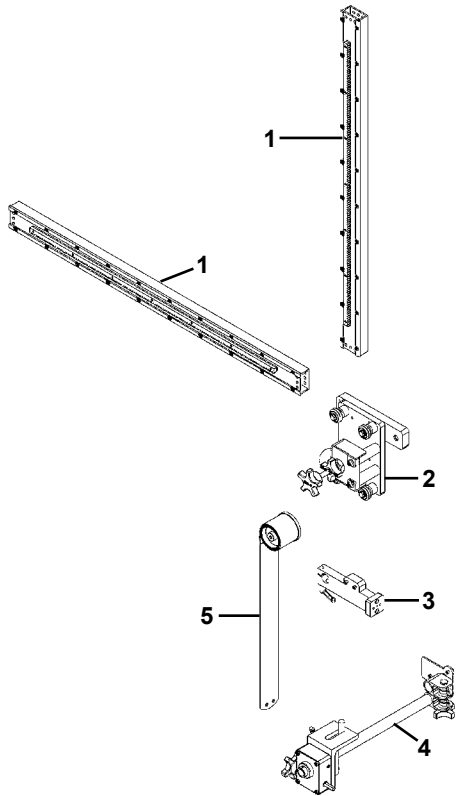

<u>ITEM</u>	<u>QTY</u>	<u>PART NO.</u>	<u>DESCRIPTION</u>
1	2	ABR-1060	V-Guide Ways 33"
2	1	CWO-1675	Vertical Racker
3	1	CWO-1695	Attachment Block
4	1	CWO-3023-1	Torch Angle Adjuster 16"
5	1	CWO-3460	24.8# Load Spring Assy.

CWO-1690 HORIZONTAL RACKER / EXPLODED VIEW / PARTS LIST

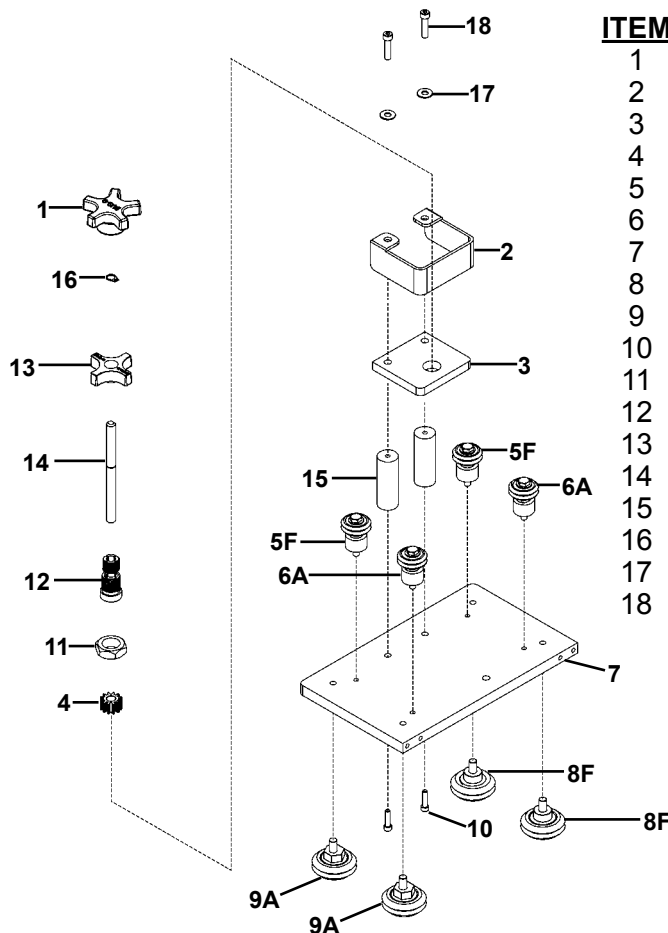

<u>ITEM</u>	<u>QTY</u>	<u>PART NO.</u>	<u>DESCRIPTION</u>
1	1	BUG-2032	Knob, Black
2	1	CWO-1671	Racker Shield
3	1	CWO-1678	Racker Plate
4	1	CWO-1679	Pinion 11T
5	2	CWO-1680	W2 Fixed Leg & Wheel Assy.
6	2	CWO-1681	W2 Adj. Leg & Wheel Assy.
7	1	CWO-1687	Mount Plate (Large Racker)
8	2	CWO-4326	Fixed Leg & Wheel Assy.
9	2	CWO-4327	Adj. Leg & Wheel Assy.
10	2	FAS-0557	Soc Hd Cap Scr 1/4-20 x 3/4"
11	1	FAS-1307	Hex Jam Nut 3/4-16
12	1	MUG-1141	Bearing Collet
13	1	MUG-1142	Knob, Locking
14	1	MUG-1144	Shaft
15	2	MUG-1453	Stand-Off
16	1	MUG-1579	Retaining Ring
17	2	WAS-0240	1/4" SAE Washer
18	2	FAS-0559	Soc Hd Cap Scr 1/4-20 x 1"

F = FIXED WHEEL PLACEMENT
A = ADJUSTABLE WHEEL PLACEMENT

CWO-2005 WIRE FEEDER GUARD / EXPLODED VIEW / PARTS LIST

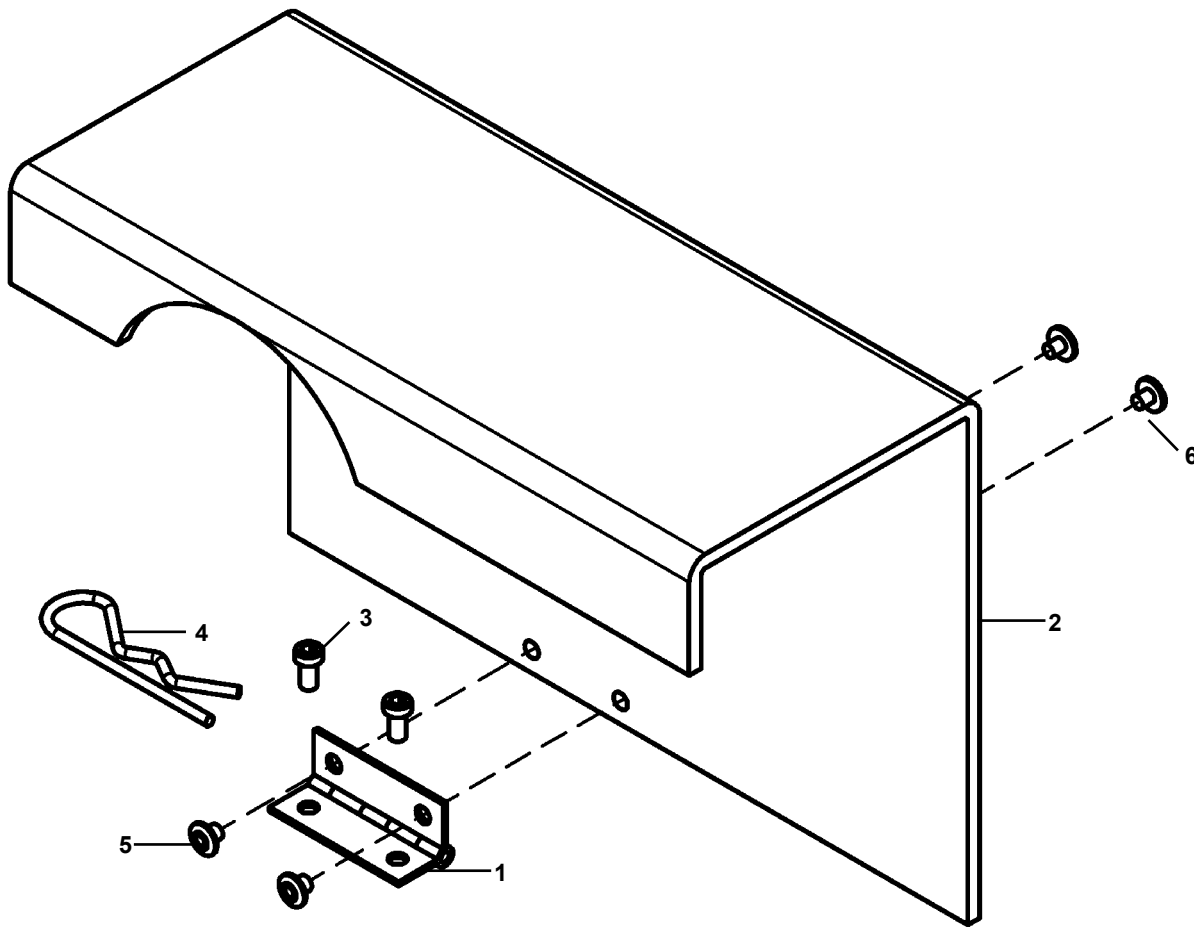

<u>ITEM</u>	<u>QTY</u>	<u>PART NO.</u>	<u>DESCRIPTION</u>
1	1	BUG-3209	Hinge 3/4" X 2" Lg
2	1	CWO-2008	Plastic Guard
3	2	FAS-0535	Soc Hd Cap 10-24 X 1/2"
4	1	HDW-1001	Steel Hair Pin Zinc Plated
5	2	BUG-3197	Binding Post, #8-32 X 3/16 Lg
6	2	BUG-3198	Binding Post Screw, #8-32 X 3/16 Lg

CWO-3027 METER KIT ASSEMBLY / EXPLODED VIEW / PARTS LIST

ITEM	QTY	PART NO.	DESCRIPTION
1	48"	900-4-001	2 Cond. 18 AWG. SJO Cord
2	1	CSR WTE 0187	Wire Strain Relief
3	1	CWO-4396	DC Volt Meter, 0-50 VDC
4	1	CWO-4397	DC AMP Meter, 0-500 ADC
5	1	CWO-4399	5" x 7" Front Meter Plate
6	1	CWO-6374	Alum. Box, Powder Coated
7	1	FAS-0145	Pan Hd Scr #10-32 x 1/2"
8	1	FAS-1340	Hex Nut #10-32
9	4	FAS-2935	Sheet Metal Scr #6 x 3/8"
10	5	TERM WTE 0294	#10 Ring, Red
11	3	TERM-0024	1/4" Red Ring
12	1	TERM-4162	1/4" Blue Ring
13	1	WAS-0231	#10 Internal Star Washer

CWO-3027 METER KIT ASSEMBLY / WIRING DIAGRAM

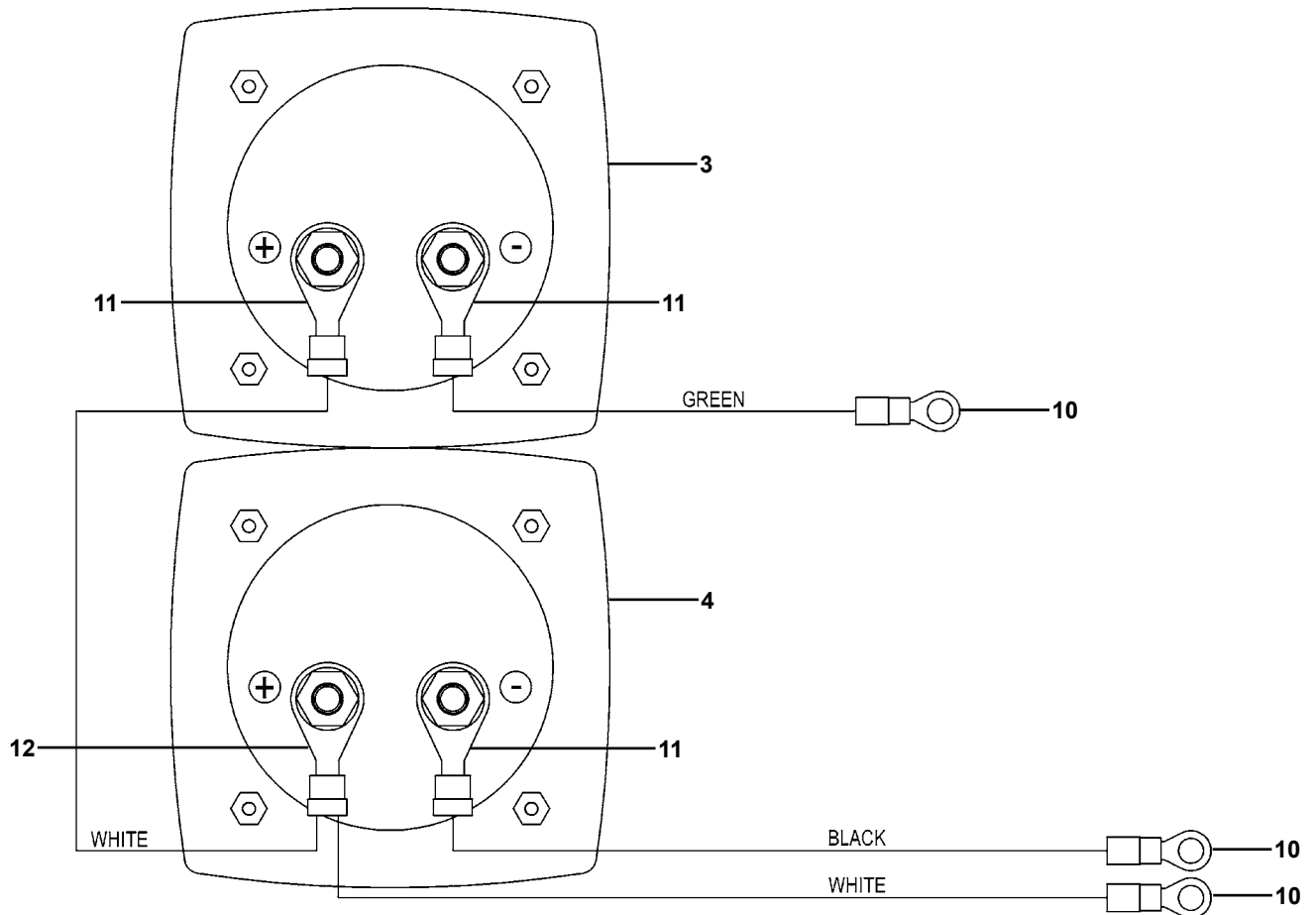

CWO-3496 SHAFT ASSEMBLY / EXPLODED VIEW / PARTS LIST

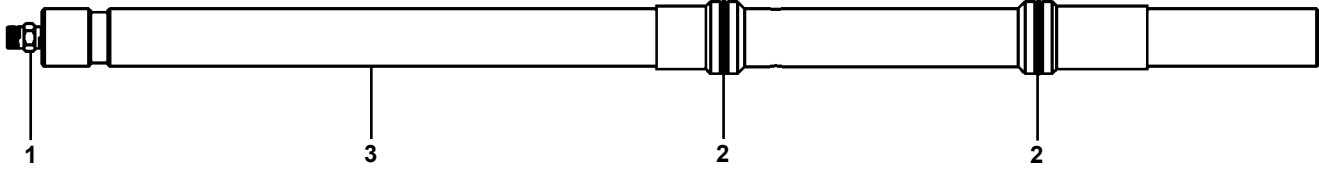

<u>ITEM</u>	<u>QTY</u>	<u>PART NO.</u>	<u>DESCRIPTION</u>
1	1	BUG-9096	Outlet Bushing, Oxygen
2	2	CWO-4049	O-Ring, Oxygen, Fuel
3	1	CWO-5778	Shaft CW-7AG / CW-7ABG

CWO-3227 CAM SHAFT & SPACER ASSEMBLY / EXPLODED VIEW / PARTS LIST

<u>ITEM</u>	<u>QTY</u>	<u>PART NO.</u>	<u>DESCRIPTION</u>
1	1	CWO-4352	Ball Joint Rod End 3/8-24 RH
2	1	CWO-5042	Ball Joint Rod End 3/8-24 LH
3	1	CWO-9081	Spacer / CW-7
4	1	CWO-9355	Pipe / Cam Shaft CW-7
5	1	FAS-0399	Hex Hd Cap Scr 3/8-16 x 1"
6	1	FAS-1395	3/8-24 Hex Jam Nut - RH
7	1	FAS-1396	3/8-24 Hex Jam Nut - LH
8	1	FAS-2396	Hex Hd Cap Scr 3/8-16 x 2-1/4"
9	3	WAS-0260	3/8" SAE Washer

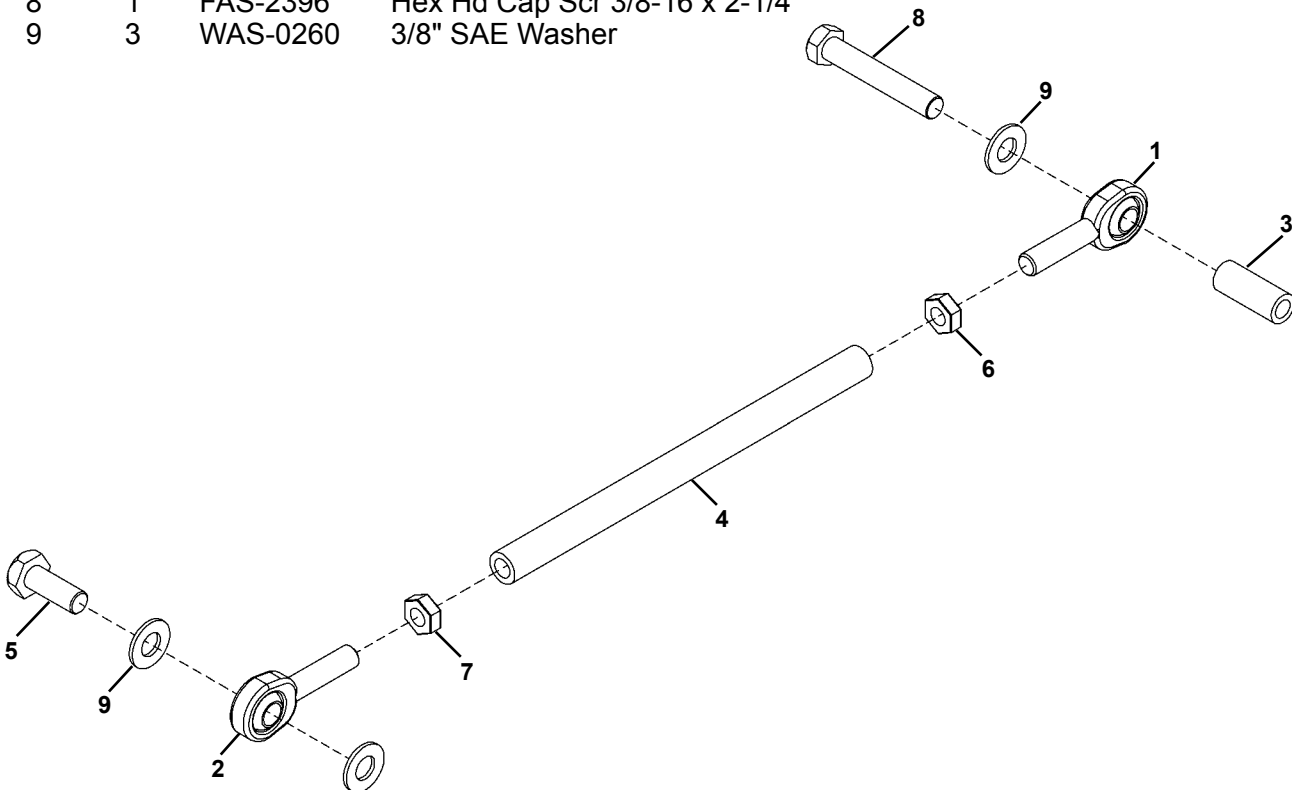

CWO-3205-11 7" CAM ASSEMBLY / EXPLODED VIEW / PARTS LIST

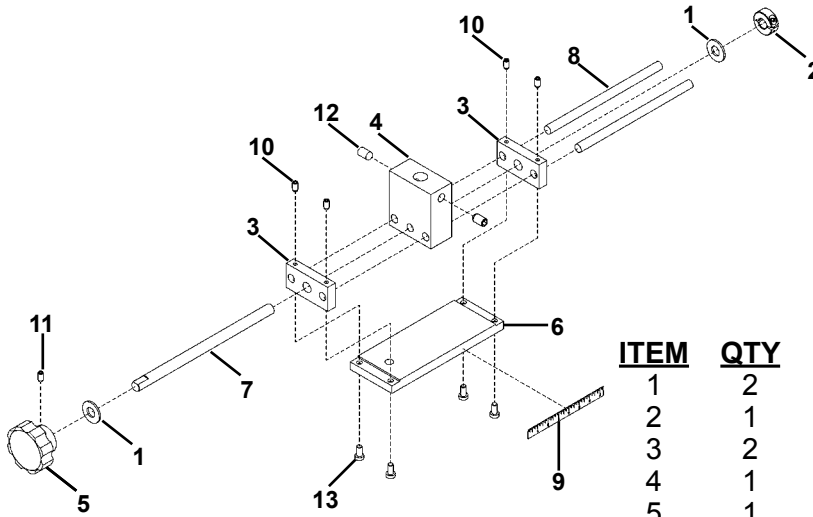

<u>ITEM</u>	<u>QTY</u>	<u>PART NO.</u>	<u>DESCRIPTION</u>
1	2	BUG-2098	Delrin Washer 3/8"
2	1	BUG-9012	Locking Collar
3	2	CWO-4027	End Plate
4	1	CWO-4028	Center Plate
5	1	CWO-4032	Knob
6	1	CWO-4328	Base Plate
7	1	CWO-4331	Screw
8	2	CWO-4332	Rod
9	1	CWO-5199	Scale
10	4	FAS-0434	Set Scr #10-24x3/8"
11	1	FAS-0444	Set Scr #10-32x3/8"
12	2	FAS-0495	Set Scr 3/8"-16x1/2"
13	4	FAS-0534	Soc Hd Cap Scr #10-24x3/8"

CWO-3498 5" WIRE REEL MOUNT ASSEMBLY / EXPLODED VIEW / PARTS LIST

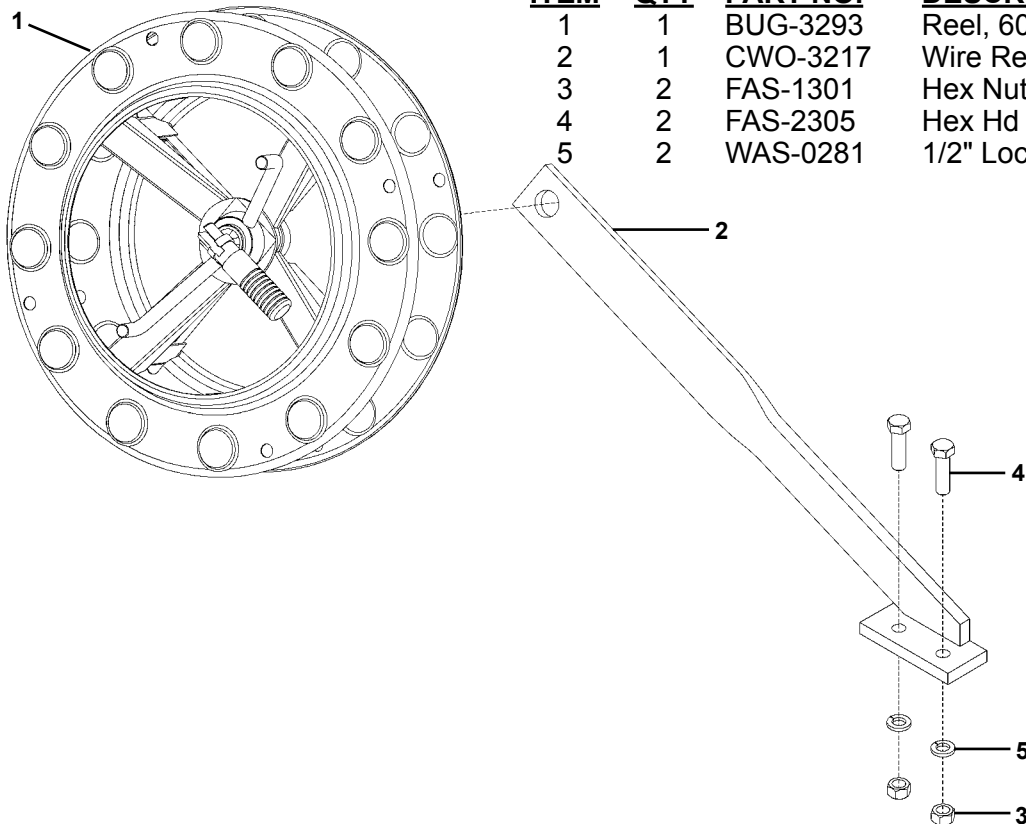

<u>ITEM</u>	<u>QTY</u>	<u>PART NO.</u>	<u>DESCRIPTION</u>
1	1	BUG-3293	Reel, 60 lbs.
2	1	CWO-3217	Wire Reel Support Assy.
3	2	FAS-1301	Hex Nut 1/2-13
4	2	FAS-2305	Hex Hd Cap Scr 1/2-13 x 1-3/4"
5	2	WAS-0281	1/2" Lock Washer

CWO-3063 LARGE BRUSH HOLDER AND SUPPORT / EXPLODED VIEW / PARTS LIST

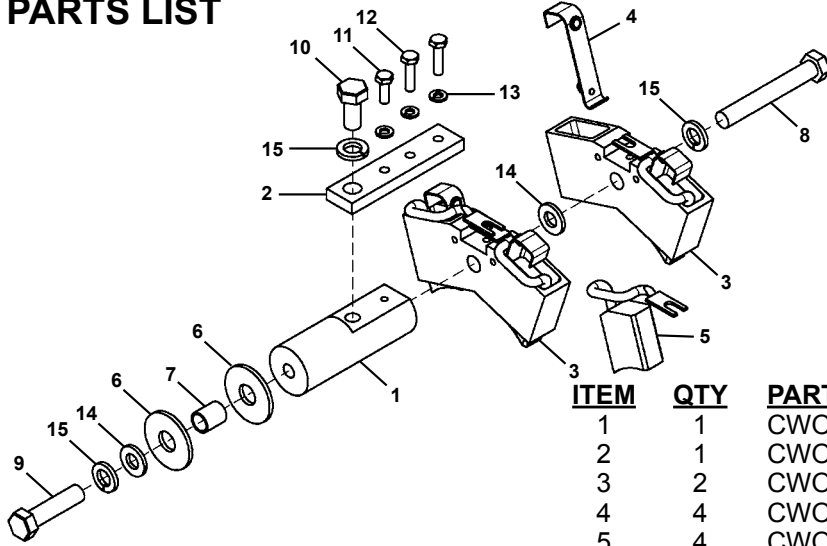

<u>ITEM</u>	<u>QTY</u>	<u>PART NO.</u>	<u>DESCRIPTION</u>
1	1	CWO-4036	Large Brush Holder Support
2	1	CWO-4339	Attachment Bar
3	2	CWO-3263	Large Brush Holder
4	4	CWO-3264	Spring Clip
5	4	CWO-4337	Large Brush 1-1/2" x 3/4" x 2"
6	2	CWO-5548	Micarta Spacer
7	1	CWO-5549	Micarta Bushing
8	1	FAS-0304	Hex Hd Cap Scr 1/2-13 x 3.5"
9	1	FAS-0305	Hex Hd Cap Scr 1/2-13 x 2"
10	1	FAS-0309	Hex Hd Cap Scr 1/2-13 x 1"
11	1	FAS-0357	Hex Hd Cap Scr 1/4-20 x 3/4"
12	2	FAS-0359	Hed Hd Cap Scr 1/4-20 x 1"
13	3	WAS-0243	1/4" Split Lock Washer
14	2	WAS-0280	1/2" SAE Flat Washer
15	3	WAS-0281	1/2" Split Lock Washer

CWO-3194 HOUSING ASSEMBLY / EXPLODED VIEW / PARTS LIST

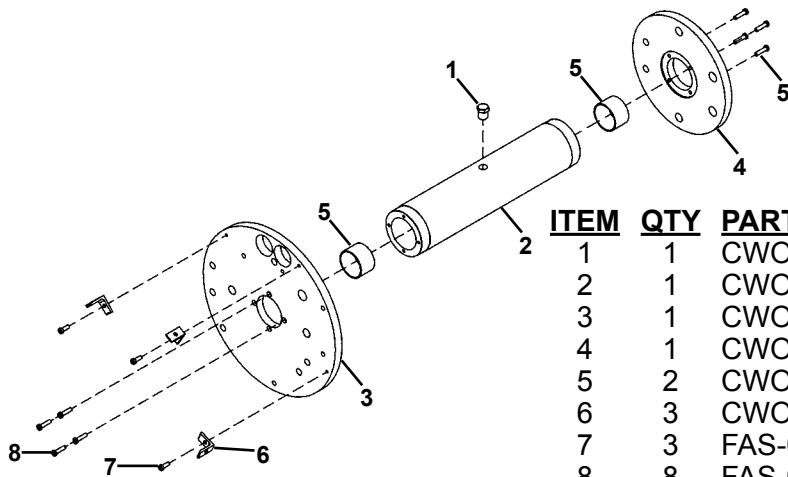

<u>ITEM</u>	<u>QTY</u>	<u>PART NO.</u>	<u>DESCRIPTION</u>
1	1	CWO-4133	1/4-18 x 1/2" NPSM Hex HD Plug, Brass
2	1	CWO-5841	Center Tube Housing CW-7
3	1	CWO-5844	Top Housing Plate CW-7
4	1	CWO-5847	Lower Housing Plate CW-7
5	2	CWO-5973	Plastic Bushing
6	3	CWO-9339	Angle For Guard
7	3	FAS-0535	Soc Hd Cap Scr 10-24 x 1/2"
8	8	FAS-0548	Soc Hd Cap Scr 10-32 x 3/4"

CWO-3361 P.M. MOTOR ASSEMBLY / EXPLODED VIEW / PARTS LIST

<u>ITEM</u>	<u>QTY</u>	<u>PART NO.</u>	<u>DESCRIPTION</u>
1	1	CWO-4067	P.M. Motor 1072
2	1	CWO-4147	P.M. Motor Bracket #970
3	1	CWO-5767	Gear, P.M. Motor
4	1	FAS-0454	Set Scr 1/4-20x3/8"
5	3	TER-WTE-1508	#8 Fork Blue 14RB-8FL-T&B

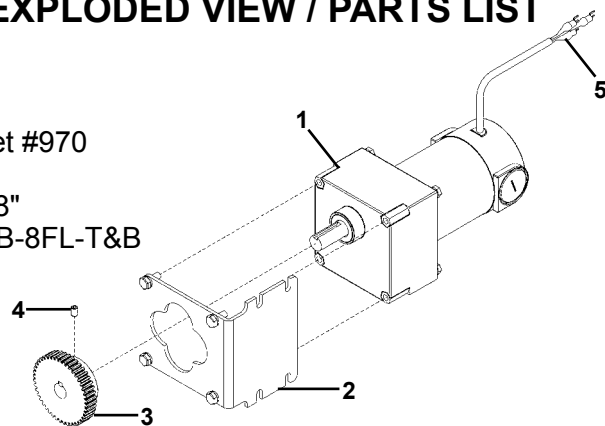

CWO-3359 TRANSMISSION 5:1 ASSEMBLY / EXPLODED VIEW / PARTS LIST

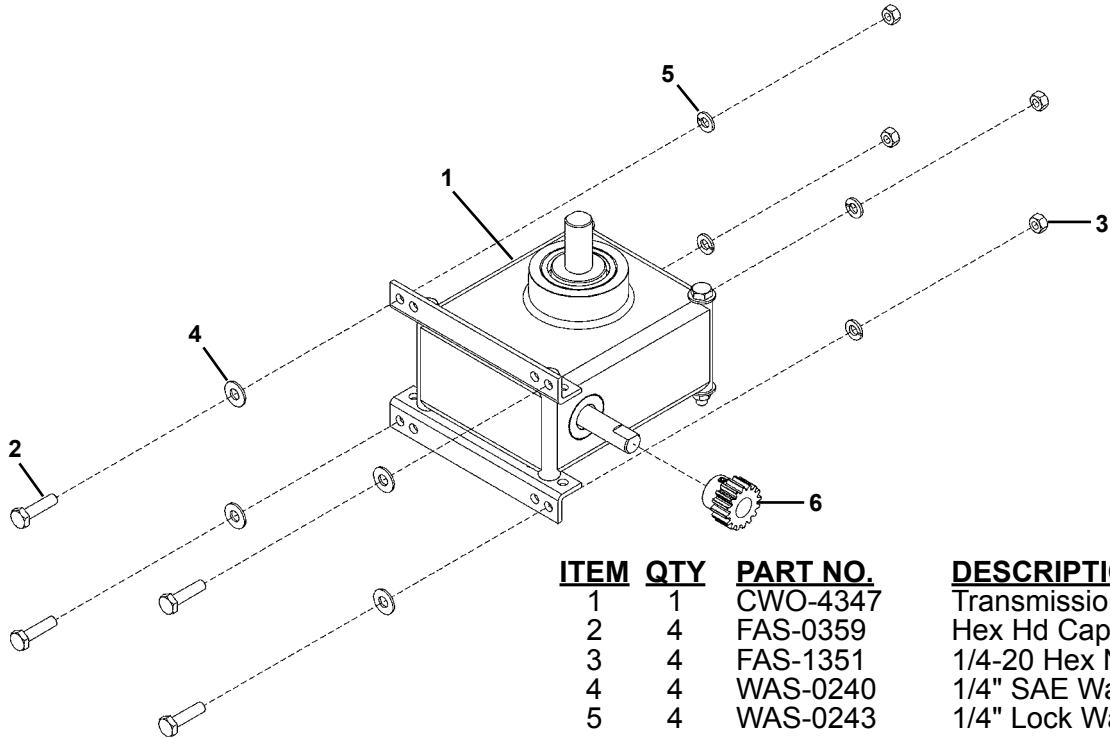

<u>ITEM</u>	<u>QTY</u>	<u>PART NO.</u>	<u>DESCRIPTION</u>
1	1	CWO-4347	Transmission 5:1
2	4	FAS-0359	Hex Hd Cap Scr 1/4-20x1"
3	4	FAS-1351	1/4-20 Hex Nut
4	4	WAS-0240	1/4" SAE Washer
5	4	WAS-0243	1/4" Lock Washer
6	1	UNI-1024	Slave Pinion

CWE-1530 SMALL BRUSH HOLDER ASSEMBLY / EXPLODED VIEW / PARTS LIST

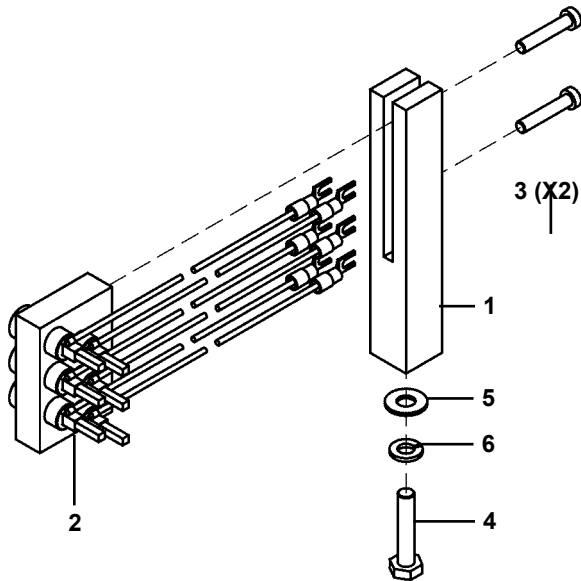

<u>ITEM</u>	<u>QTY</u>	<u>PART NO.</u>	<u>DESCRIPTION</u>
1	1	CWE-1531	Retainer Support Small
2	1	CWE-1532	6 Pos Small Ret. Block Assy.
3	2	FAS-2351	Soc Hd Cap Scr 10-24x1"
4	1	FAS-0539	Hex Hd Cap Scr 1/4-20x1 1/4"
5	1	WAS-0240	1/4" SAE Flat
6	1	WAS-0243	1/4" Split Lock Washer

CWO-3461 SMALL RETAINER BLOCK ASSEMBLY / DETAIL VIEW

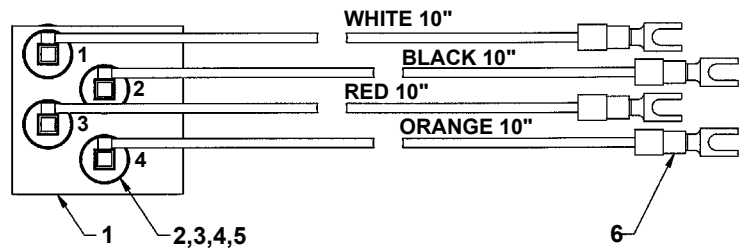

<u>ITEM</u>	<u>QTY</u>	<u>PART NO.</u>	<u>DESCRIPTION</u>
1	1	CWO-5626	Small Brush Retainer Blk
2	4	CWO-5831	Brush 1/8" x 1/8" x 7/8"
3	4	CWO-5874	Brush Holder
4	4	CWO-5875	Cap
5	4	CWO-5876	Clip
6	4	TERM WTE 0602	#6 Fork Blue

CWO-3332 GMA WIRE FEEDER CONTROL / EXPLODED VIEW / PARTS LIST

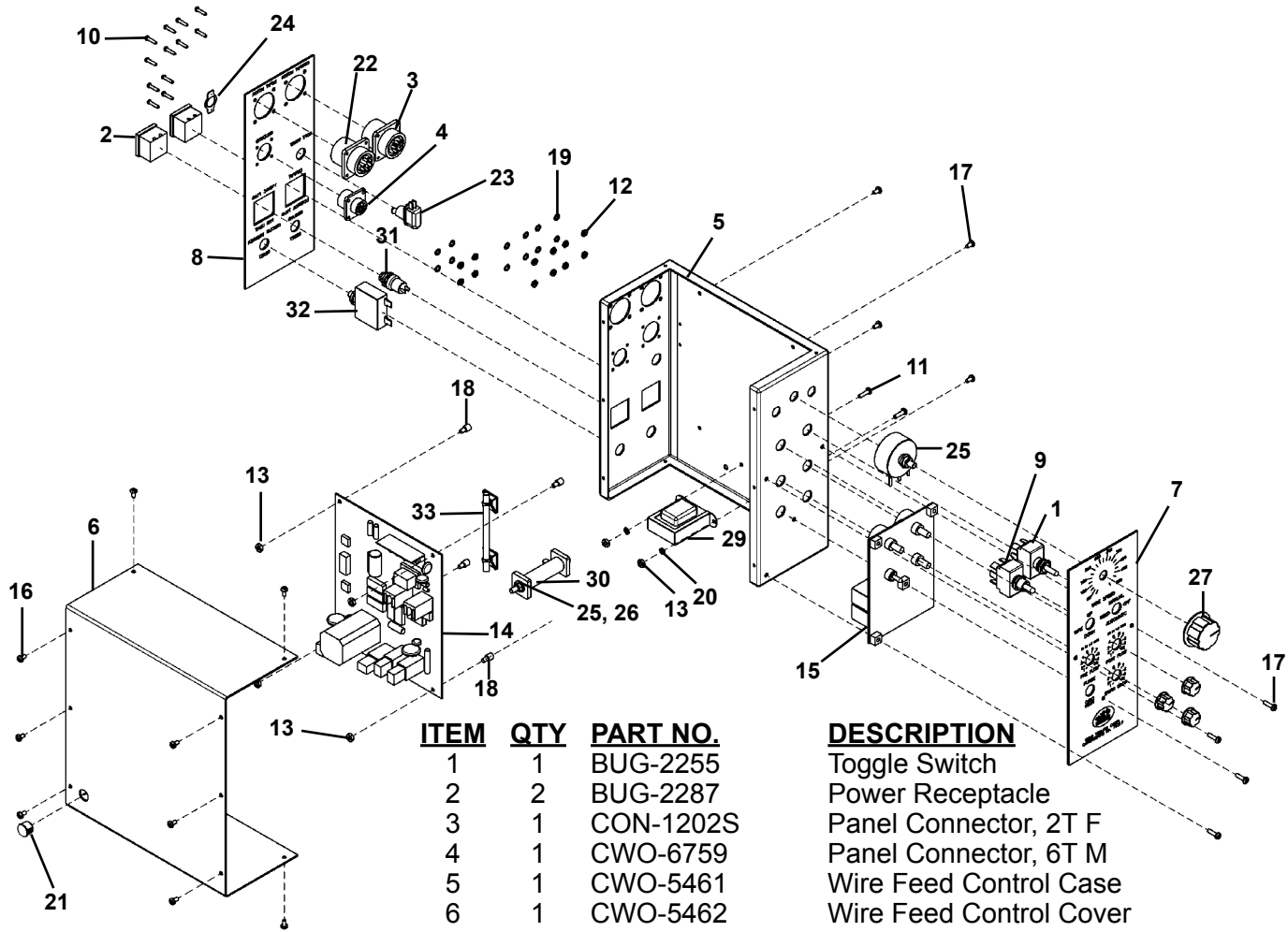

ITEM	QTY	PART NO.	DESCRIPTION
1	1	BUG-2255	Toggle Switch
2	2	BUG-2287	Power Receptacle
3	1	CON-1202S	Panel Connector, 2T F
4	1	CWO-6759	Panel Connector, 6T M
5	1	CWO-5461	Wire Feed Control Case
6	1	CWO-5462	Wire Feed Control Cover
7	1	CWO-5533A	Wire Feed Front Panel
8	1	CWO-5533B	Wire Feed Rear Panel
9	1	CWO-6335	Toggle Switch
10	12	FAS-0205	Rnd Hd Scr 4-40 X 1/2"
11	2	FAS-0215	Rnd Hd Scr #6-32 X 1/2"
12	12	FAS-1305	Hex Nut 4-40
13	6	FAS-1310	Hex Nut #6-32
14	1	LN7 WTE 1351	Motor Control Board
15	1	PCB-1350	Timing Control Board
16	10	SCW WTE 1435	Pan Hd Scr #6-32 X 1/4"
17	4	SCW WTE 0481	Pan Hd Scr #6-32 X 1/2"
18	4	STOF-2009	Stand Off #6-32
19	12	WAS-0201	#4 Internal Star Lock Washer
20	2	WAS-0211	#6 Internal Star Lock Washer
21	1	MUG-1589	Hole Plug .522"
22	1	MS-2A18-11S	Panel Connector, 5T M
23	1	ABP-1069	Toggle Switch
24	1	BUG-9884	On-Off Switch Plate
25	1	LDC-1113	Plain Washer for LN-7
26	2	LDC-1114	Hex Nut 10-24 for LN-7
27	1	LDC-1104	Knob for LN-7
28	1	LDC-1103	Potentiometer for LN-7
29	1	LDC-1107	Transformer & Lead Assembly
30	1	LDC-1109	Resistor for LN-7
31	1	LDC-1108	Switch for LN-7
32	1	LN7 WTE 1352	Circuit Breaker 250V 2.5A
33	1	LDC-1101	Reed Switch Assy for LN-7

CWO-3332 GMA WIRE FEEDER CONTROL / WIRING DIAGRAM

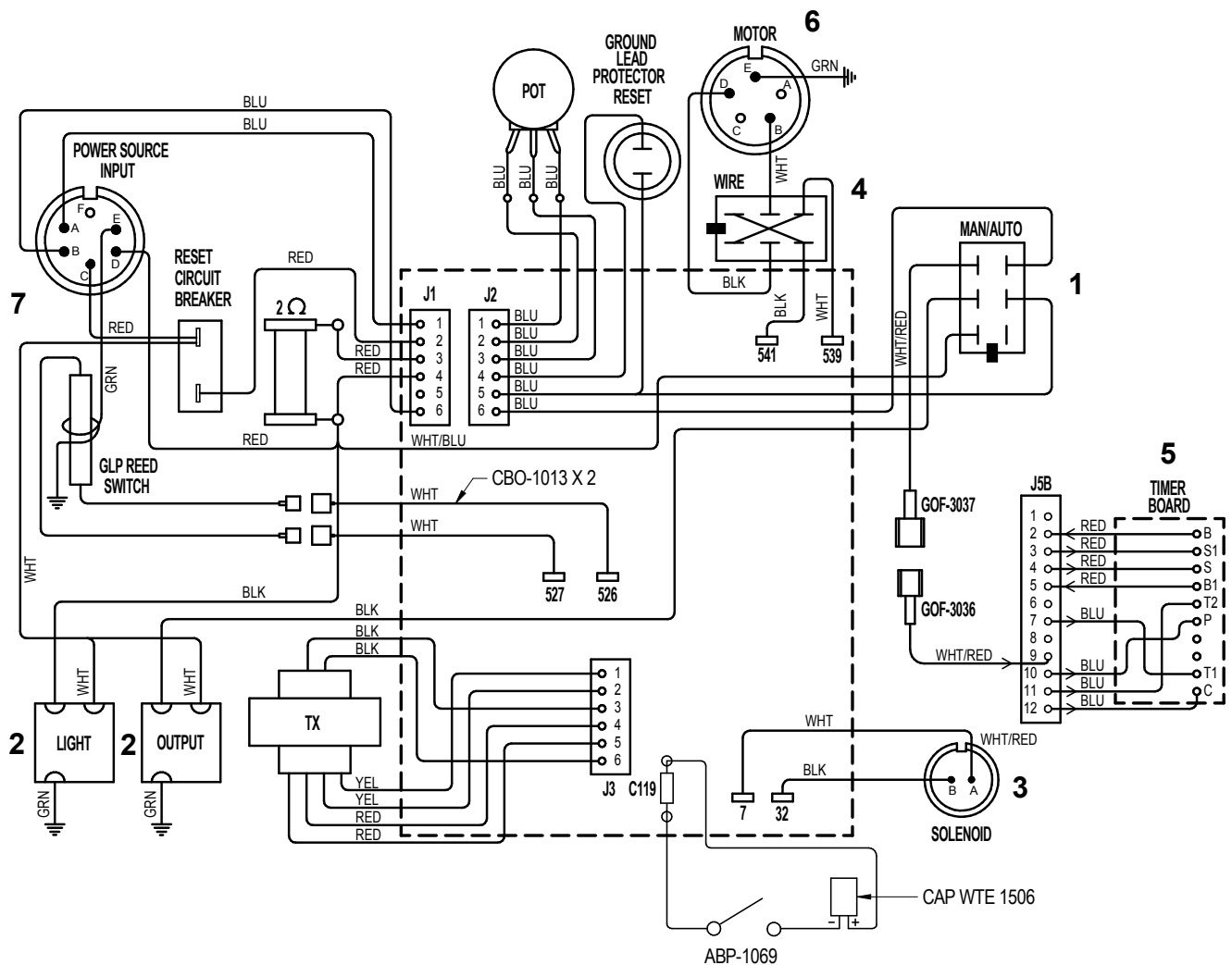

ELECTRICAL COMPONENT CHART		
ITEM	DESCRIPTION	PART NO.
1	Toggle Switch ON-Off-ON	BUG-2255
2	Power Receptacle	BUG-2287
3	Panel Connector 2T-F	CON-0384
4	Toggle Switch ON-NONE-ON	CWO-6335
5	Timer Board	PCB-1350
6	Panel Connector 5T, F	MS-2A18-11S
7	Panel Connector, 6T, Male	CWO-6759

--- = INDICATES CONTROL BOARD ITEMS THAT ARE NOT USER REPLACEABLE.

CWO-6210 ROTATION CONTROL / EXPLODED VIEW / PARTS LIST

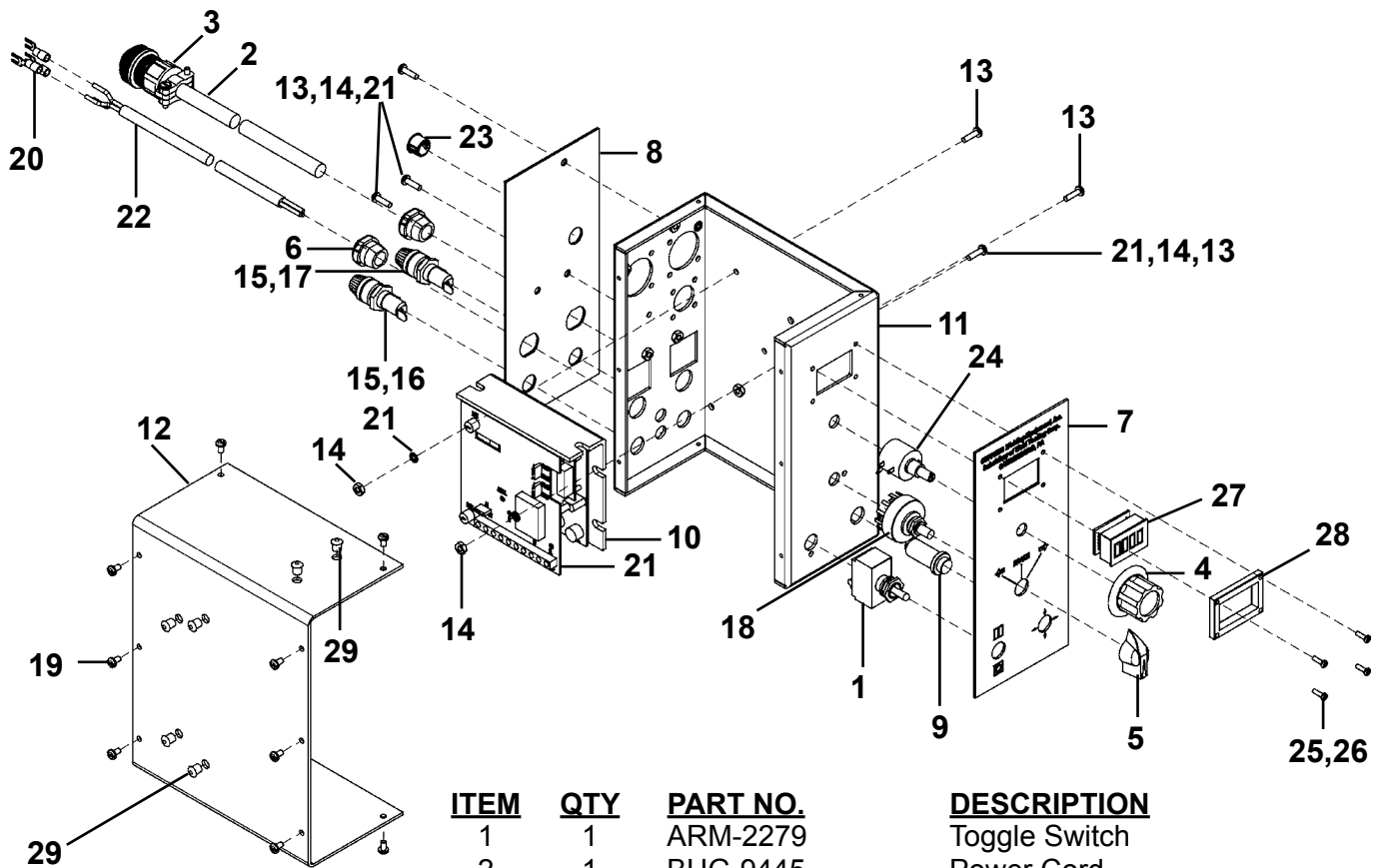

<u>ITEM</u>	<u>QTY</u>	<u>PART NO.</u>	<u>DESCRIPTION</u>
1	1	ARM-2279	Toggle Switch
2	1	BUG-9445	Power Cord
3	1	CON-PS04M	Plug, Straight 4-Pin Male
4	1	BUG-9687	Knob Fluted
5	1	BUG-9694	Knob
6	2	CSR-WTE-1597	Cord Strain Relief
7	1	CWO-6216	Rotation Box Front Panel
8	1	CWO-5547B	Rotation Box Rear Panel
9	1	CWO-6206	Indicator Light
10	1	CWO-6527	0-90V Spd Ctrl W.Isolator
11	1	CWO-6839	Rotation Control Case
12	1	CWO-6802	Rotation Box Cover
13	6	FAS-0115	#6-32 x 1/2" Pan Head Zinc
14	6	FAS-1310	Hex Nut 6-32
15	2	FHO-0188	Fuse Holder
16	1	MPD-1026	Fuse 2 Amp
17	1	FUS-0257	Fuse 3 Amp
18	1	MUG-1258-1	Rotary Switch Assembly
19	10	SCW-WTE-0264	#6-32 x 1/4" Sht Mt Scr
20	3	TERM-WTE-0197	#6 Red Fork
21	6	WAS-0211	#6 Internal Star Washer
22	42"	WRE-WTE-0501	18/3 SJO 300V Cord
23	1	MUG-1589	Hole Plug .500"
24	1	BUG-1562	Multi-turn Potentiometer
25	4	FAS-0401	#4-40 X 3/8" Pan Hd
26	4	SCF-1001	#4-40 Self Clinching Nut
27	1	BUG-1764	Meter Display Board
28	1	MDS-1011	Display Bezel
29	6	BUG-3331	Hole Plug 1/4"

CWO-6210 ROTATION CONTROL / WIRING DIAGRAM / ELECTRICAL COMPONENT CHART

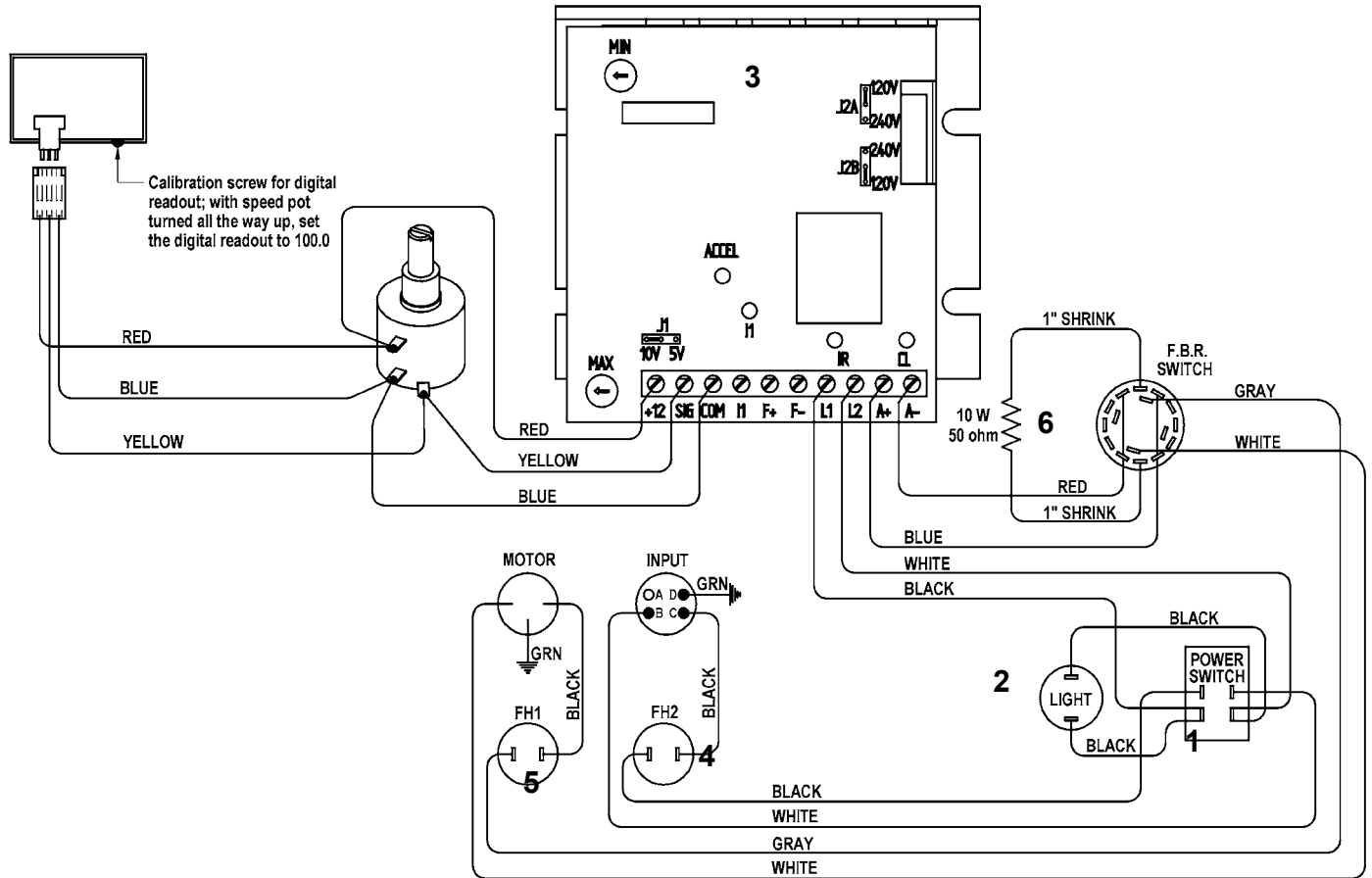

--- = INDICATES ITEMS THAT ARE SUPPLIED TOGETHER.

ELECTRICAL COMPONENT CHART		
ITEM	DESCRIPTION	PART NO.
1	Toggle Switch	ARM-2279
2	Red Neon Lamp	CWO-6206
3	Speed Control Board w/Resistor	CWO-6525
4	Fuse 2 amp	MPD-1026
5	Fuse 3 amp	FUS-0257
6	Rotary Switch	MUG-1258-1

CW-7 GUN ASSEMBLIES (MIG/FLUX-CORED)

CWO-1560-A #5 .035 GUN ASSEMBLY MIG/FLUX .035 WIRE SIZE

CWO-8027	15H-35 CONTACT TIP	10
CWO-8034	25CT-75 NOZZLE	1
CWO-8035	35CT NOZZLE INSULATOR	1
CWO-8036	55 SW GAS DIFFUSER	1
CWO-8039	45-3545-15 CABLE LINER	1
CWO-8524	50394 500 AMP CABLE	1

CWO-1560-B #5 .045 GUN ASSEMBLY MIG/FLUX .045 WIRE SIZE

CWO-8028	15H-45 CONTACT TIP	10
CWO-8034	25CT-75 NOZZLE	1
CWO-8035	35CT NOZZLE INSULATOR	1
CWO-8036	55 SW GAS DIFFUSER	1
CWO-8039	45-3545-15 CABLE LINER	1
CWO-8524	50394 500 AMP CABLE	1

CWO-1560-C #5 1/16 GUN ASSEMBLY MIG/FLUX 1/16 WIRE SIZE

CWO-8029	15H-116 CONTACT TIP	10
CWO-8034	25CT-75 NOZZLE	1
CWO-8035	35CT NOZZLE INSULATOR	1
CWO-8037	55 GAS DIFFUSER	1
CWO-8041	45-116-15 CABLE LINER	1
CWO-8524	50394 500 AMP CABLE	1

CWO-1560-D #5 5/64 GUN ASSEMBLY MIG/FLUX 5/64 WIRE SIZE

CWO-8031	15H-564 CONTACT TIP	10
CWO-8034	25CT-75 NOZZLE	1
CWO-8035	35CT NOZZLE INSULATOR	1
CWO-8038	55 GAS DIFFUSER	1
CWO-8085	45-564-15 CABLE LINER	1
CWO-8524	50394 500 AMP CABLE	1

CWO-1560-E #5 3/32 GUN ASSEMBLY MIG/FLUX 3/32 WIRE SIZE

CWO-8032	15H-332 CONTACT TIP	10
CWO-8034	25CT-75-NOZZLE	1
CWO-8035	35CT NOZZLE INSULATOR	1
CWO-8042	45H-332-15 CABLE LINER	1
CWO-8038	55H-GAS DIFFUSER	1
CWO-8524	50394 500 AMP CABLE	1

CWO-1560-G #5 .052 GUN ASSEMBLY MIG/FLUX .052 WIRE SIZE

CWO-8024	15H-52 CONTACT TIP	10
CWO-8034	25CT-75 NOZZLE	1
CWO-8035	35CT NOZZLE INSULATOR	1
CWO-8036	55 SW GAS DIFFUSER	1
CWO-8041	45-116-15 CABLE LINER	1
CWO-8524	50394 500 AMP CABLE	1

CW-7 GUN ASSEMBLIES (SUB ARC)

CWO-1700-A #5 .035 GUN ASSEMBLY SUB ARC .035 WIRE SIZE

CWO-8027	15H-35 CONTACT TIP	10
CWO-8036	55 SW GAS DIFFUSER	1
CWO-8039	45-3545-15 CABLE LINER	1
CWO-8054	25-SA NOZZLE FLUX CONE	1
CWO-8524	50394 500 AMP CABLE	1

CWO-1700-B #5 .045 GUN ASSEMBLY SUB ARC .045 WIRE SIZE

CWO-8028	15H-45 CONTACT TIP	10
CWO-8036	55 SW GAS DIFFUSER	1
CWO-8039	45-3545-15 CABLE LINER	1
CWO-8054	25-SA NOZZLE FLUX CONE	1
CWO-8524	50394 500 AMP CABLE	1

CWO-1700-C #5 1/16 GUN ASSEMBLY SUB ARC 1/16 WIRE SIZE

CWO-8029	15H-116 CONTACT TIP	10
CWO-8037	55 GAS DIFFUSER	1
CWO-8041	45-116-15 CABLE LINER	1
CWO-8054	25-SA NOZZLE FLUX CONE	1
CWO-8524	50394 500 AMP CABLE	1

CWO-1700-D #5 5/64 GUN ASSEMBLY SUB ARC 5/64 WIRE SIZE

CWO-8031	15H-564 CONTACT TIP	10
CWO-8038	55 GAS DIFFUSER	1
CWO-8042	45-116-15 CABLE LINER	1
CWO-8054	25-SA NOZZLE FLUX CONE	1
CWO-8524	50394 500 AMP CABLE	1

CWO-1700-E #5 3/32 GUN ASSEMBLY SUB ARC 3/32 WIRE SIZE

CWO-8032	15H-332 CONTACT TIP	10
CWO-8038	55H-GASS DIFFUSER	1
CWO-8042	45-332-15 LINER	1
CWO-8054	25-SA NOZZLE FLUX CONE	1
CWO-8524	50394 500 AMP CABLE	1

CWO-1700-G #5 .052 GUN ASSEMBLY SUB ARC .052 WIRE SIZE

CWO-8024	15H-52 CONTACT TIP	10
CWO-8036	55 SW GAS DIFFUSER	1
CWO-8041	45-116-15 CABLE LINER	1
CWO-8054	25-SA NOZZLE FLUX CONE	1
CWO-8524	50394 500 AMP CABLE	1

CW-7 DRIVE ROLL KITS

PART NO.	DESCRIPTION
CWO-7026-.035	DRIVE ROLL KIT .035 (0.9mm) SOLID WIRE
CWO-7026-.035C	DRIVE ROLL KIT .035 (0.9mm) CORED WIRE
CWO-7026-.052	DRIVE ROLL KIT .045-.052 (1.0-1.3mm) SOLID WIRE
CWO-7026-.052C	DRIVE ROLL KIT .045-.052 (1.0-1.3mm) CORED WIRE
CWO-7026-1/16	DRIVE ROLL KIT 1/16 (1.6mm) SOLID/CORED WIRE
CWO-7026-3/32	DRIVE ROLL KIT .068-3/32 (1.7-2.4mm) SOLID/CORED WIRE

CWO-3690-_ K231 SUBARC GUN ASSEMBLY / EXPLODED VIEW / PARTS LIST

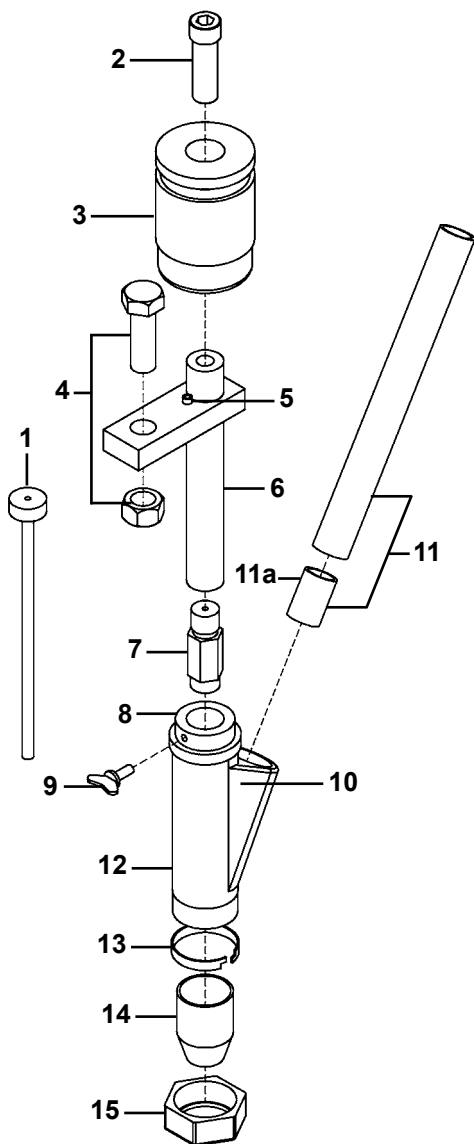

ITEM	QTY	PART NO.	DESCRIPTION
1	1	PXS-15106-3/32	Nozzle Insert
2	1	PXT-10570	Socket Head Screw
3	1	PXS-10493-1	Nozzle Insulator
4	1	PXS-121312	Hex Hd Scr 1 1/2" & Nut 1/2"-13
5	1	PXT-9967-10	Nozzle Body Roll Pin
6	1	CWO-8052	Nozzle Body
7	1	PXS-10125-_	Contact Tip (Specify Wire Size)
8	1	PXS-10138	Flux Cone Plug (Insulator)
9	1	PXT-9078-1	Thumb Screw
10	1	PXT-9967-30	Flux Cone Roll Pin
11	1	PXT-13835	3/4"X7" Flux Hose W/Fbr Ins
11A	1	PXT-3835-IN	Fiber Insulator
12	1	BUG-3161-P	Cone Body Assembly
13	1	BUG-3163	Locking Ferrule
14	1	BUG-3164	Flux Cone (Kp2085-1)
15	1	BUG-3165	Retaining Nut

*WIRE SIZES AVAILABLE:

PART NO.	WIRE SIZE
CWO-3690-1/16	1/16" (1.6 mm)
CWO-3690-5/64	5/64" (2.0 mm)
CWO-3690-3/32	3/32" (2.4 mm)

*REPLACEMENT CONTACT TIPS AVAILABLE:

PART NO.	WIRE SIZE
AFW-2291	1/16" (1.5 mm)
CWO-8048	5/64" (2.0 mm)
CWO-8049	3/32" (2.4 mm)

CWO-3700-_ SUBARC GUN ASSEMBLY / EXPLODED VIEW / PARTS LIST

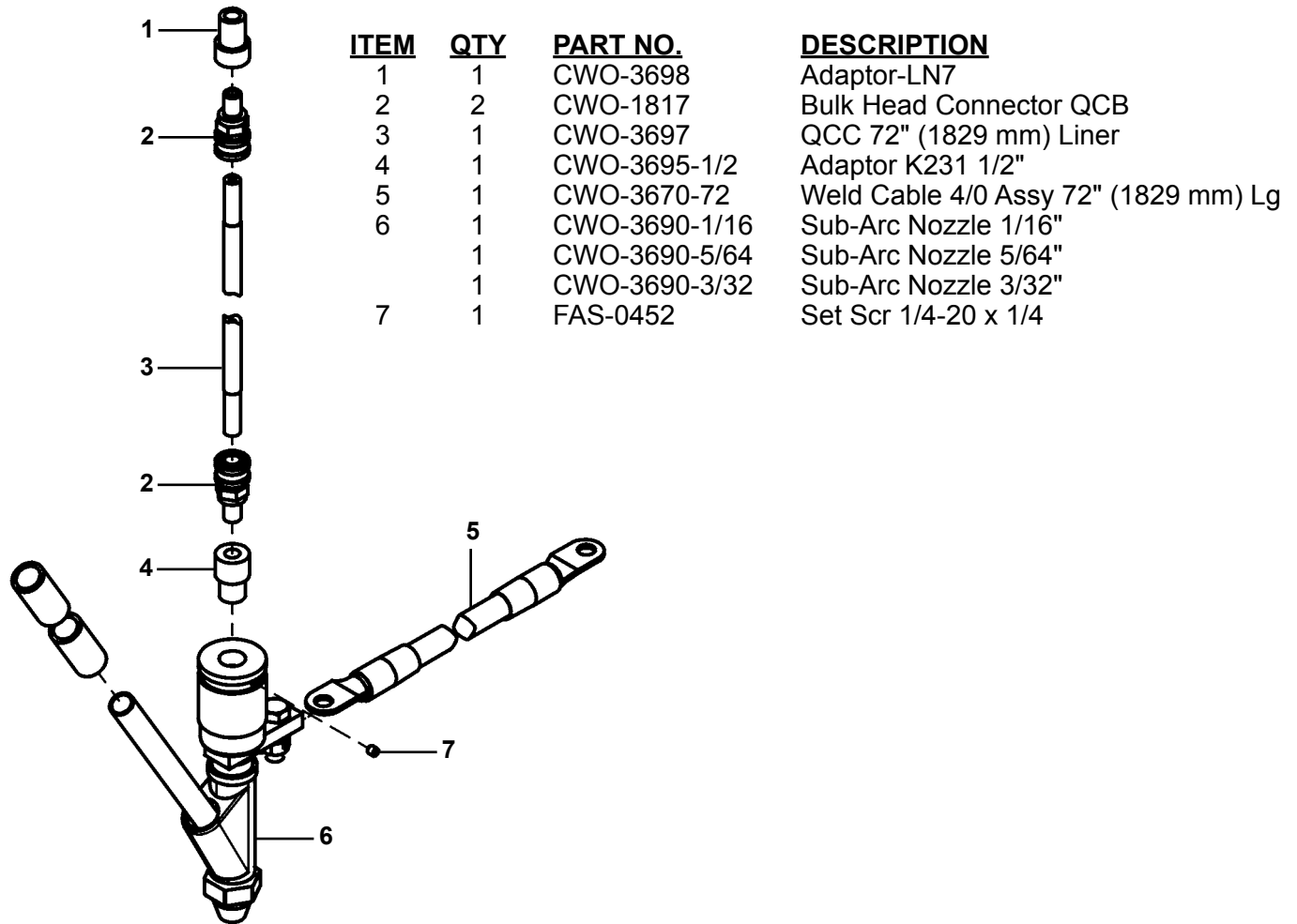

CWO-3490 CW-7 FLUX HOPPER ASSEMBLY / EXPLODED VIEW / PARTS LIST

ITEM	QTY	PART NO.	DESCRIPTION
1	1	CWO-3757	Hopper Support Rod
2	1	CWO-3760	Clamp Block 1/2"
3	1	CWO-3478	3/4" Hose Barb
4	1	CWO-3769	Flux Hopper Steel 12"
5	1	GOF-3019	Handle w/Bolts
N/S	48"	1000-4-001	3/4" ID x 1" OD Clear Hose

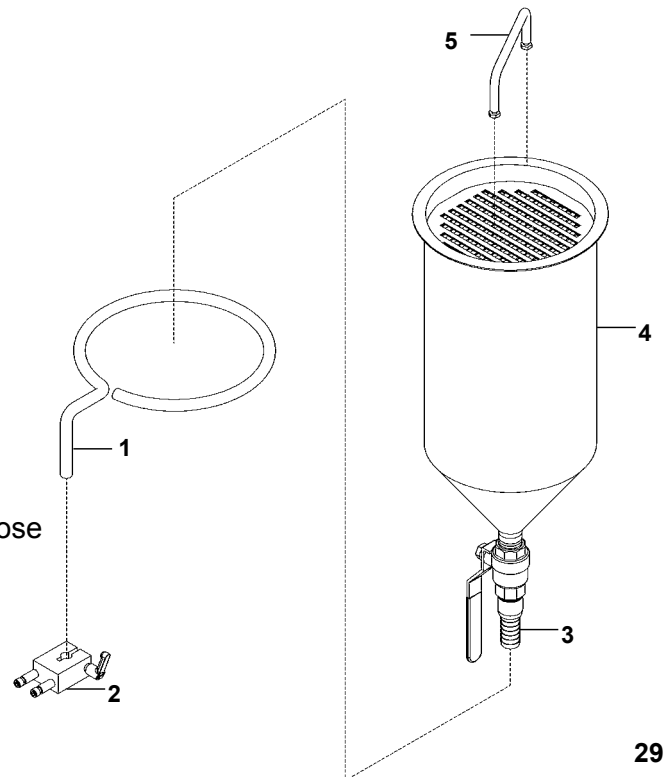

#5 GUN AND CABLE ASSEMBLY / EXPLODED VIEW / PARTS LIST

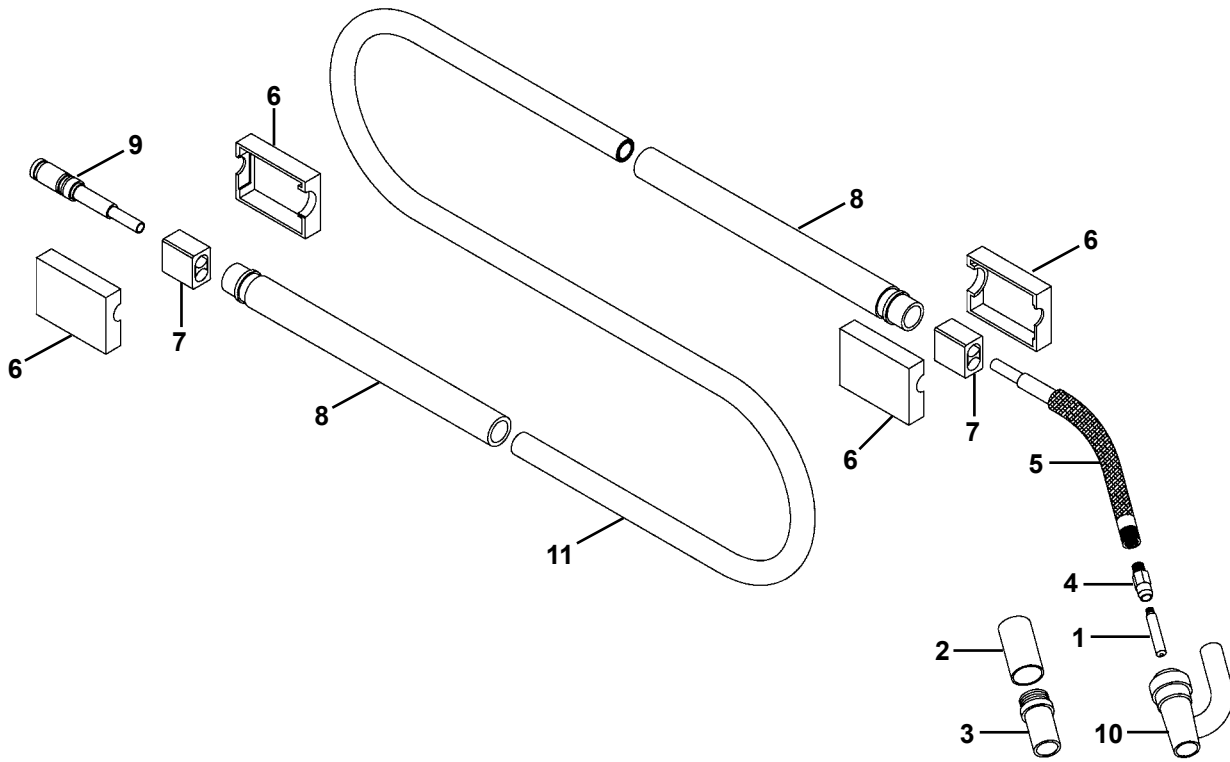

PARTS LIST				WIRE SIZE					
ITEM	QTY	PART #	DESCRIPTION	.035	.045	.052	1/16	5/64	3/32
1	1	CWO-8024	15H-52 Contact tip			X			
1	1	CWO-8027	15H-35 Contact Tip	X					
1	1	CWO-8028	15H-45 Contact Tip		X				
1	1	CWO-8029	15H-116 Contact Tip				X		
1	1	CWO-8031	15H-564 Contact Tip					X	
1	1	CWO-8032	15H-332 Contact Tip						X
2	1	CWO-8034	25CT-75 Nozzle Insulator	X	X	X	X	X	X
3	1	CWO-8035	35CT Nozzle Insulator	X	X	X	X	X	X
4	1	CWO-8036	55SW Gas Diffuser	X	X	X			
4	1	CWO-8037	55 Gas Diffuser				X		
4	1	CWO-8038	55H Gas Diffuser					X	X
5	1	CWO-8045	65-60 Conductor Tube	X	X	X	X	X	X
6	2	CWO-8017	185 Case w/Binder Screws	X	X	X	X	X	X
7	2	CWO-8018	104 Cable Connector Block	X	X	X	X	X	X
8	1	CWO-8052	Cable Hose Support	X	X	X	X	X	X
9	1	CWO-8053	175 Connector Plug w/O-Rings	X	X	X	X	X	X
10	1	CWO-8054	25-SA Nozzle Flux Cone	X	X	X	X	X	X
11	1	CWO-8524	50394 500 AMP Cable	X	X	X	X	X	X
*	1	CWO-8039	45-4535-15 Cable Liner	X	X				
*	1	CWO-8041	45-116-15 Cable Liner			X	X		
*	1	CWO-8042	45-332-15 Cable Liner						X
*	1	CWO-8085	45-564-15 Cable Liner					X	

* ITEMS NOT SHOWN

3-JAW EXPANDABLE CHUCKS

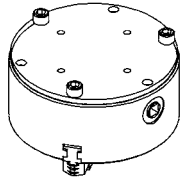

CWO-3660

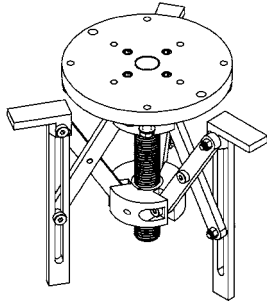

CWO-3661

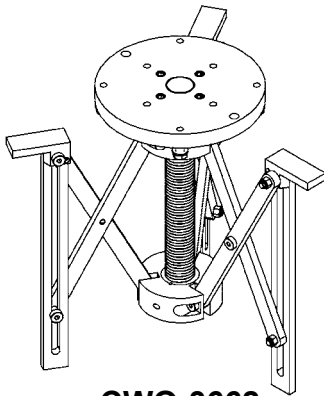

CWO-3662

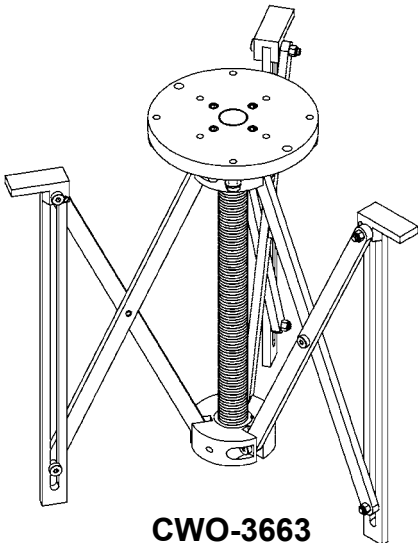

CWO-3663

3-Jaw Expandable Chucks

Mounts and automatically centers the Circle Welder on nozzles with or without flanges. As shown below.

PART NO.	FOR NOZZLE I.D.'S	WEIGHT
CWO-3660	2"-10" (51mm-254mm)	69.3 lbs. (31.3 kg)
CWO-3661	8"-16" (204-405 mm)	36 lbs. (16 kg)
CWO-3362	10"-24" (255-610 mm)	51 lbs. (23 kg)
CWO-3663	15.75"-47.25" (400-1200 mm)	64 lbs. (29 kg)

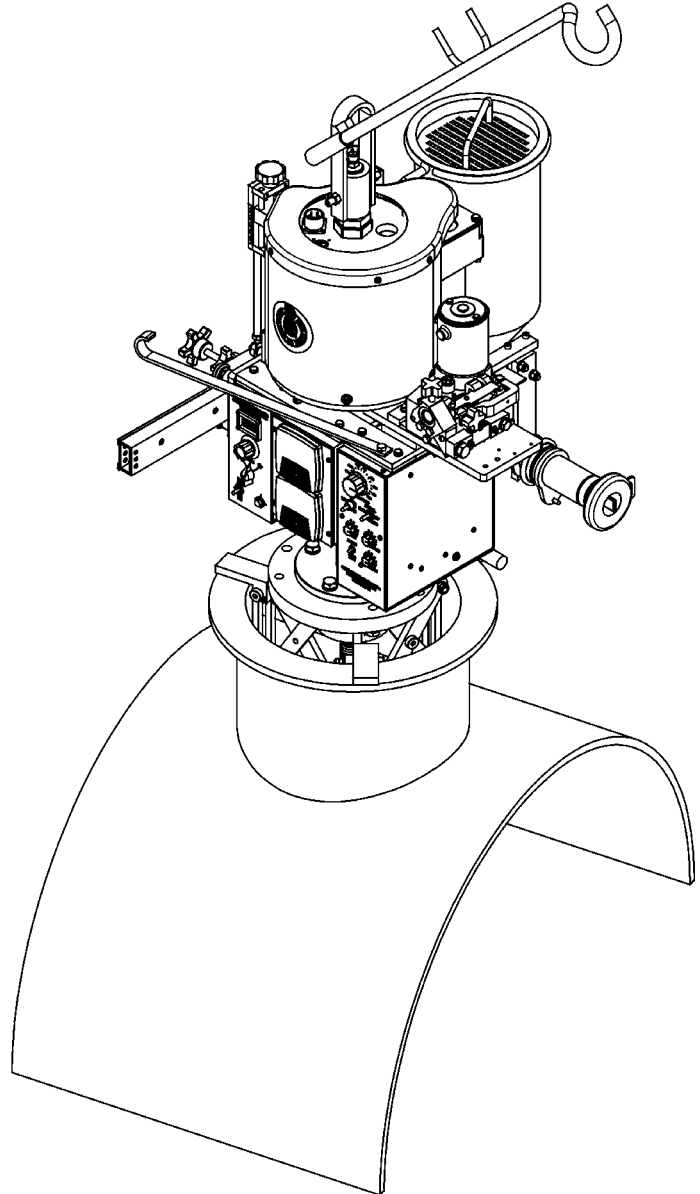

OPTIONAL MOTORIZED RACKING EQUIPMENT / CWO-1665-MV / EXPLODED VIEW / PARTS LIST

<u>ITEM</u>	<u>QTY</u>	<u>PART NO.</u>	<u>DESCRIPTION</u>
1	1	ABR-1060-MH	Motorized Horizontal V-Guide Ways 33"
2	2	ABR-1060-MV	Motorized Vertical V-Guide Ways 33"
3	1	CWO-1675-MV	Motorized Vertical Racker
4	1	CWO-1695	Attachment Block
5	1	CWO-3023-1	Torch Angle Adjuster 16"
6	1	CWO-3460	33# Load Spring Assembly

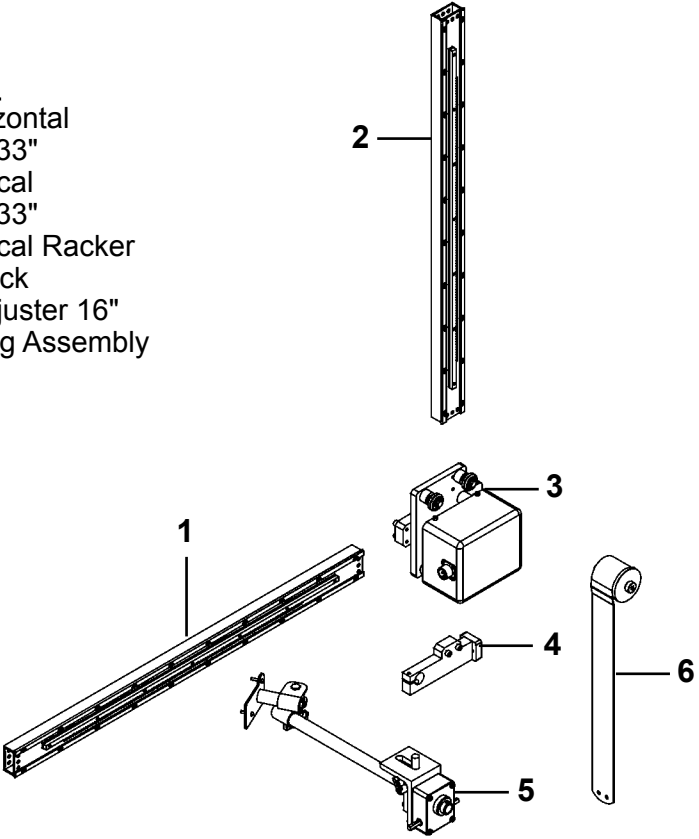

OPTIONAL MOTORIZED RACKING EQUIPMENT / CWO-1690-MH / EXPLODED VIEW / PARTS LIST

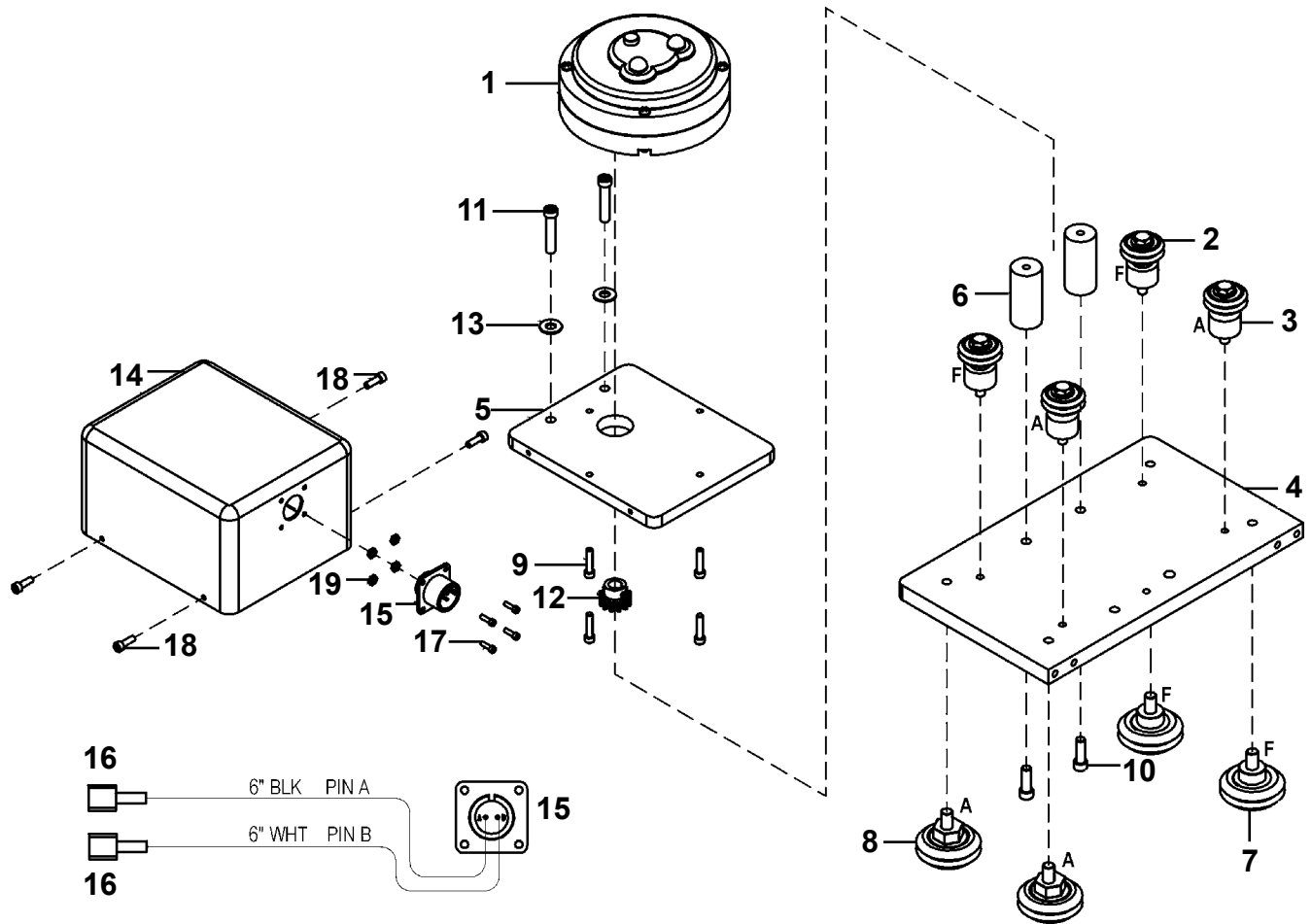

<u>ITEM</u>	<u>QTY</u>	<u>PART NO.</u>	<u>DESCRIPTION</u>
1	1	BUG-1550	Gear Motor (150:1)
2	2	CWO-1680	W2 Fixed Leg & Wheel
3	2	CWO-1681	W2 Adj. Leg & Wheel
4	1	CWO-1687	Mount Plt Large Racker
5	1	CWO-1693	Racker Motor MT Plt
6	2	CWO-1694	Stand-Off
7	2	CWO-4326	Fixed Leg & Wheel
8	2	CWO-4327	Adj. Leg & Wheel
9	4	FAS-0527	Soc Hd Cap 8-32 x 3/4"
10	2	FAS-0557	Soc Hd Cap 1/4-20 x 3/4"
11	2	FAS-0559	Soc Hd Cap 1/4-20 x 1"
12	1	GOF-3014	Drive Pinion w/ Key
13	2	WAS-0240	1/4" SAE Washer
14	1	CWO-1696	Motor Enclosure
15	1	BUG-9486	Panel Connector 2-T, M
16	2	GOF-3036	QD Female
17	4	FAS-0504	Soc Hd Cap 4-40 x 3/8"
18	4	FAS-0525	Soc Hd Cap 8-32 x 1/2"
19	4	FAS-1305	Hex Nut 4-40

OPTIONAL RACKING MOTORIZED RACKING / CWP-3350 / EXPLODED VIEW / PARTS LIST

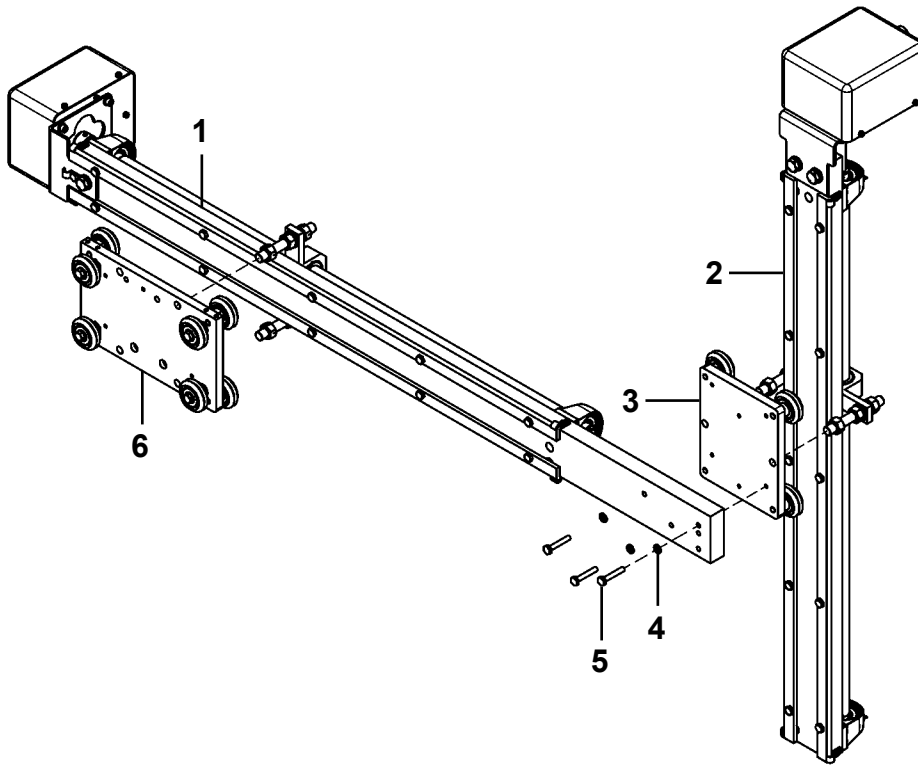

<u>ITEM</u>	<u>QTY</u>	<u>PART NO.</u>	<u>DESCRIPTION</u>
1	1	CWP-3351	Motorized Vertical Heavy Duty Rack Assy.
2	1	CWP-3352	Motorized Vertical Heavy Duty Rack Assy.
3	1	CWP-3360	Vertical Racker for Heavy Duty
4	3	WAS-0243	1/4 Split Lock Washer
5	3	FAS-2353	Hex Hd Cap Scr 1/4-20x1-1/2
6	1	CWP-3363	Horizontal Racker for Heavy Duty
*7	1	CWO-3976	Power Racker Cable

*Not shown in drawing

OPTIONAL RACKING MOTORIZED RACKING / CWP-3351 / EXPLODED VIEW / PARTS LIST

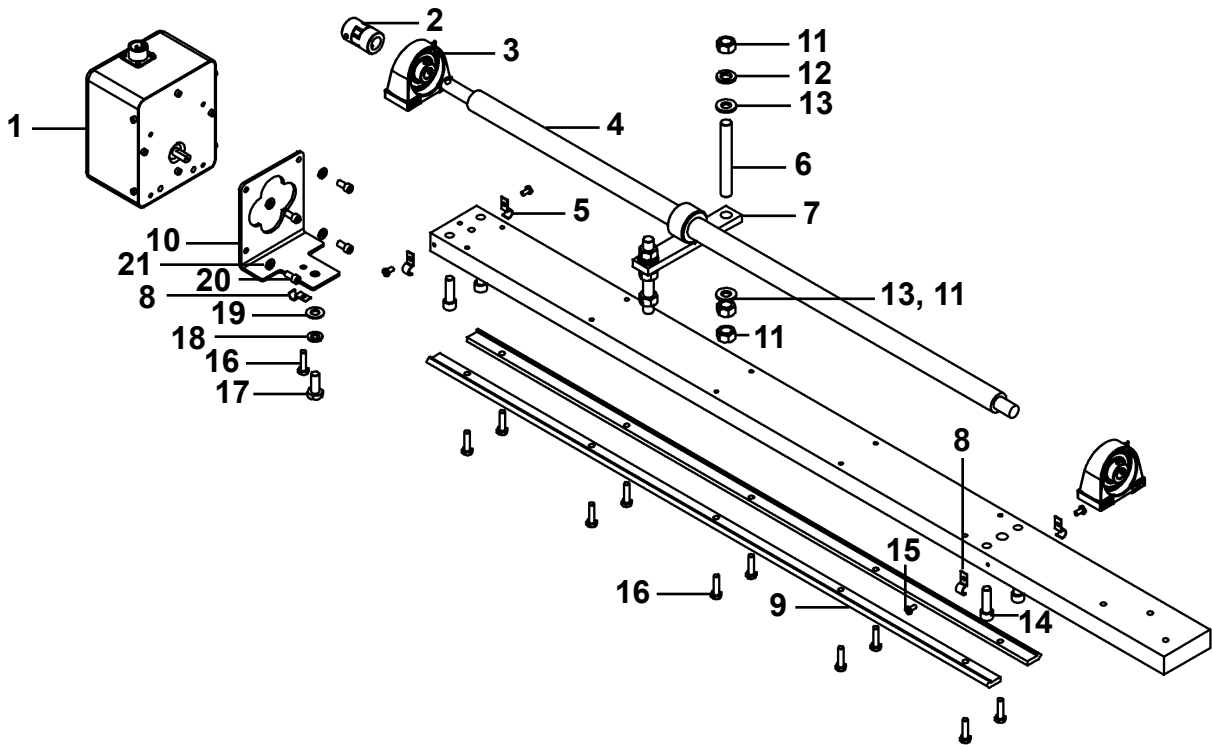

<u>ITEM</u>	<u>QTY</u>	<u>PART NO.</u>	<u>DESCRIPTION</u>
1	1	CWP-3355	Hvy Duty Rack 150:1 No Mounting Bracket
2	1	CWO-5933	Jaw Coupling 3/8" & 5/8" Bores With Spider
3	2	CWO-5565	5/8" Pillow Block
4	1	CWP-3354	Screw for Mtrzd Hrzd Hvy Duty Rack
5	1	CWP-3353	Mtrzd Hrzd Slide Hvy Duty Rack
6	2	CWP-3362	Stud 1/2-13 All Thread
7	1	CWO-3865	1"-6 Acme Nut and Bar Assembly
8	5	CWO-9038	Hold Down Clip
9	2	CWO-9065	T-3 Track 36" Lg
10	1	CWP-3356	Horiz P.M. Motor Bracket #970 Mod
11	6	FAS-1301	Hex Nut 1/2-13
12	2	WAS-0281	1/2 Split Lockwasher Zinc Plated
13	4	WAS-0280	1/2 SAE Flat
14	4	FAS-2591-SS	Soc Hd Cap Scr 3/8-16 x 1-1/4 Stainless Steel
15	4	FAS-1444-SS	Phil Pan Hd Scr 10/32 x 3/8" Stainless Steel
16	10	FAS-0359-SS	Hex Hd Cap Scr 1/4-20 x 1" Stainless Steel
17	1	FAS-0399	Hex Hd Cap Scr 3/8-16 x 1"
18	1	WAS-0262	3/8" Split Lock Washer Zinc Plated
19	1	WAS-0260	3/8 Washer Zinc Plated
20	4	FAS-0555	Soc Hd Cap Scr 1/4-20 x 1/2
21	4	WAS-0243	1/4" Split Lock Washer Zinc Plated

OPTIONAL MOTORIZED RACKING EQUIPMENT / PRS-1100/ EXPLODED VIEW / WIRING DIAGRAM

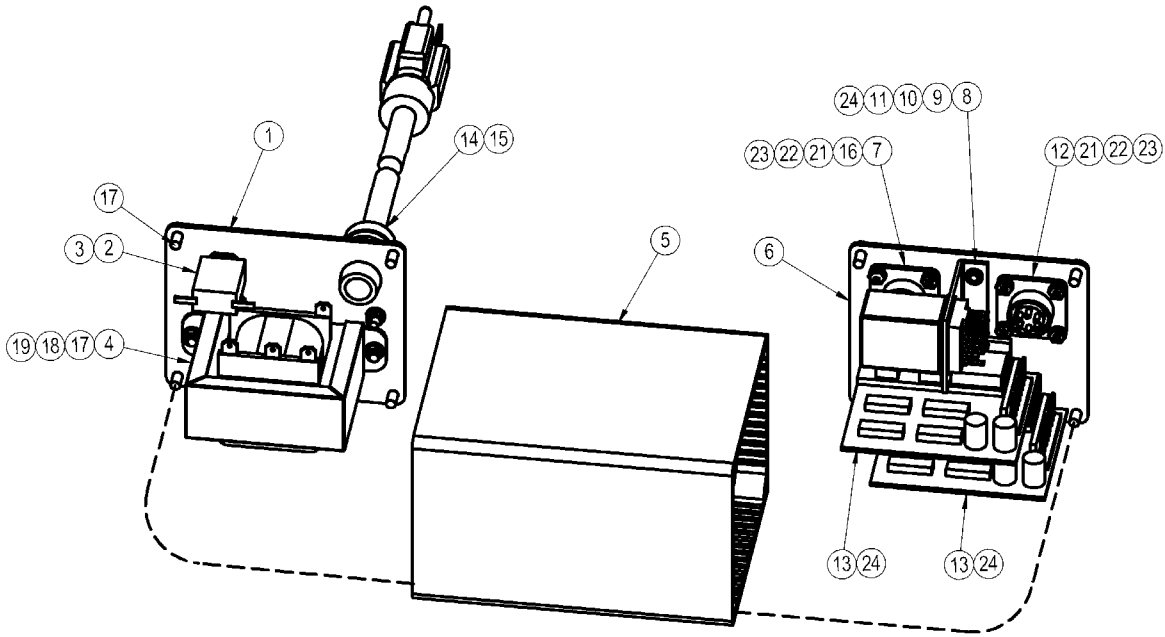

ITEM	DESCRIPTION	PRS-1091	PRS-1093	PRS-1095
		120 VAC PART NO	240 VAC PART NO	42 VAC PART NO
T	Transformer	BUG-5001	BUG-5002	BUG-5003
CB	Circuit Breaker	BUG-2923	BUG-2952	BUG-2933
VT	Volt Trap	BUG-1393	BUG-1563	BUG-1393
PC	Power Cord	BUG-9445	GOF-3115	BUG-9442
R	Relay	BUG-1383	BUG-1551	BUG-9636

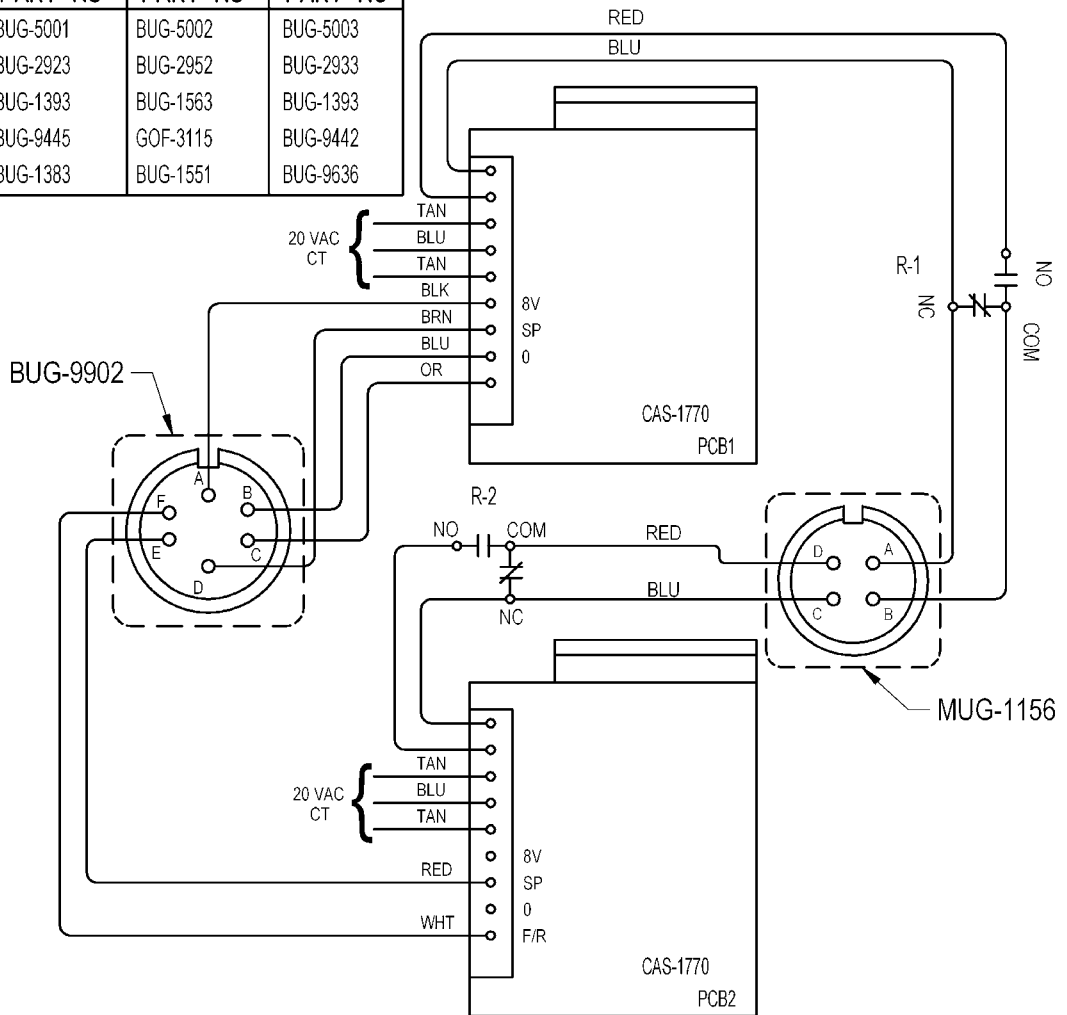
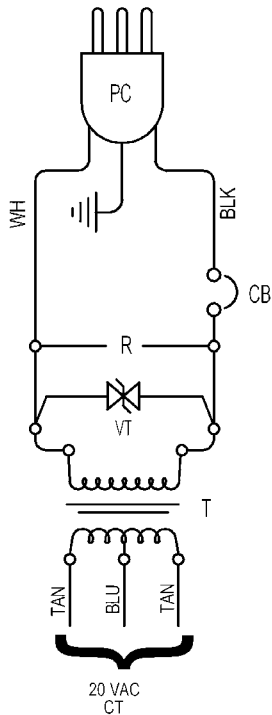

OPTIONAL MOTORIZED RACKING EQUIPMENT / PRS-1100 / PARTS LIST

ITEM	COMPONENT ITEM	DESCRIPTION	120VAC	240VAC	42VAC
1	PRS-1111	Input End Panel	1		
2	BUG-2923	.7 Amp Circuit Breaker	1		
	BUG-2952	.5 Amp Circuit Breaker		1	
	BUG-2933	2 Amp Circuit Breaker			1
3	BUG-2924	"Reset Seal, Transparent"	1		
4	BUG-5001	Transformer 115VAC	1		
	BUG-5002	Transformer 240VAC		1	
	BUG-5003	Transformer 42VAC			1
5	PRS-1110	Enclosure	1		
6	PRS-1112	Output End Panel	1		
7	MUG-1156	Panel Connector, 4-T, F	1		
8	BUG-1404	Relay Bracket	1		
9	BUG-1411	Hold Down Spring	1		
10	BUG-1384	Relay Socket & Spring	1		
11	BUG-1383	Relay, 4Pdt, 3A 120V, Plug In	1		
	BUG-1551	Relay 3A, 240VAC		1	
	BUG-9636	Relay 48VAC			1
12	BUG-9902	Panel Connector, 6-T, F	1		
13	CAS-1770	Speed Control (Iron Rotor)	2		
14	BUG-9446	Cord Grip	1		
15	BUG-9445	Power Cord (120VAC Shown)	1		1
	GOF-3115	Line Cord 240VAC		1	
16	BUG-9628	Cap & Chain Assy	1		
17	FAS-0124	8/32 X 3/8 Pan Hd, Di-Chrome	10		
18	FAS-1320	Hex Nut 8-32	3		
19	WAS-0221	#8 Internal Star Lockwasher	3		
20	SCW WTE 0514	#8-32 X 3/8" Pan Head, Zinc	1		
21	FAS-0204	Rnd Hd Slit Scr 4-40 X 3/8 Zinc	8		
22	FAS-1305	Hex Nut 4-40	8		
23	WAS-0201	#4 Internal Star Lockwasher	8		
24	FAS-0112	Pan Hd Slit 6-32 X 1/4 Black	6		
N/S	SFX-1292	Bumper, Cylindrical .14 X .50"	4		

OPTIONAL MOTORIZED RACKING EQUIPMENT / CWP-3363 / EXPLODED VIEW / PARTS LIST

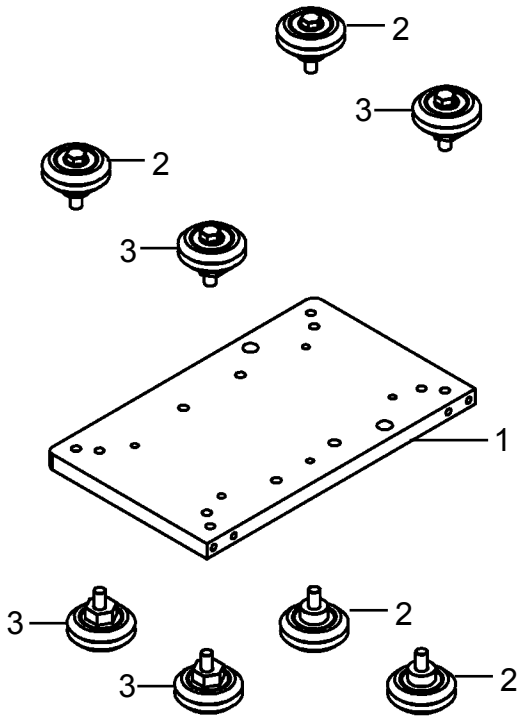

<u>ITEM</u>	<u>QTY</u>	<u>PART NO.</u>	<u>DESCRIPTION</u>
1	1	CWO-1687	Plate
2	4	CWO-4326	Wheel & Leg Assy., Fixed
3	4	CWO-4327	Wheel & Leg Assy., Adjustable

OPTIONAL MOTORIZED RACKING EQUIPMENT / PRS-1075 / EXPLODED VIEW / PARTS LIST

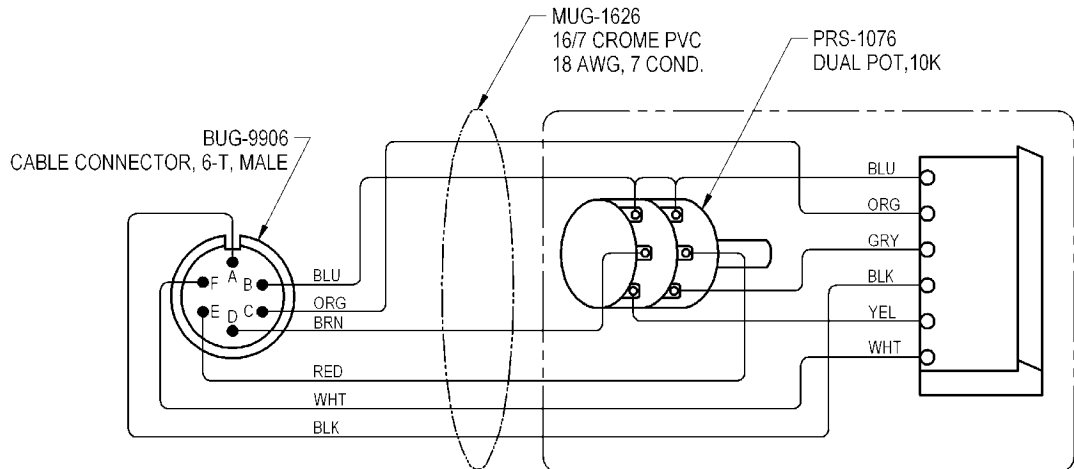
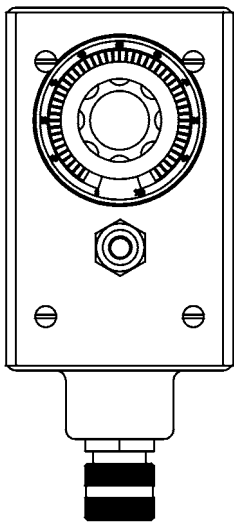

PREVENTIVE MAINTENANCE / CW-7 CIRCLE WELDER

IMPORTANT: Make sure the input power at the power source is turned off and the 50' weld cable is disconnected from the circle welder prior to working inside the circle welder.

AFTER DAILY USE:

Refer to CW-7 Exploded View Parts List. (Pg. 10, 11)

Racking System Item #1:

Inspect gear rack, hardened ways and wheels, remove all dirt, grease, weld spatter and rust. Check hardened ways for nicks and replace if necessary. Lubricate with a dry teflon or graphite spray lubricant. Adjust wheels for snug fit and smooth operation. Lubricate racker pinion with a dry teflon or graphite spray lubricant.

Large Horizontal Racker Item #2:

Inspect wheels and remove all dirt, grease, weld spatter and rust. Adjust wheels for snug fit and smooth operation. Lubricate racker pinion and wheels with a dry teflon or graphite spray lubricant.

Slide Bar Mounting Assembly Item #6:

Inspect hardened ways remove all dirt, grease and weld spatter. Check hardened ways for nicks and replace if necessary. Lubricate with a dry teflon or graphite spray lubricant.

Refer to CW-7 Electrical Component Chart. (Pg. 12)

Power Cable Item #4:

Inspect cable connector to make sure threads are not stripped and that the connector is not cracked. Check the cable for cuts, missing insulation and burn spots, replace if necessary.

CW-7 Collector Ring Item #11:

Inspect cable connector to make sure threads are not stripped and that the connector is not cracked. Ensure that the connector is fastened properly to the large aluminum gear item #27 on the CW-5 Exploded View Parts List.

EVERY SIX MONTHS:

Refer to CW-7 Exploded View Parts List. (Pg. 10, 11)

Aluminum Gear Item #29

Do not grease this gear. Inspect gear teeth remove all dirt, grease and weld spatter. Lubricate with a dry teflon or graphite spray lubricant. Replace gear if excessively worn.

P.M. Motor Assembly Item #17:

Do not grease this pinion. Inspect the drive pinion. Remove all dirt, grease and weld spatter. Lubricate with a dry teflon or graphite spray lubricant. Replace pinion if excessively worn. Check set screw and tighten if necessary. Adjust motor assembly using the four adjustable mounting fasteners so that proper gear mesh is achieved between the aluminum gear item #29 and the motor drive pinion.

5" Cam Assembly Item #7:

Inspect the slide rails and the cam pinion. Remove all dirt, grease and weld spatter. Do not grease slide rails or cam pinion. Lubricate with a dry teflon or graphite spray lubricant. Replace cam pinion if excessively worn. Tighten all fasteners as needed.

Wire Reel Assembly Item #22:

Periodically coat the wire wheel shaft with a thin layer of grease as needed. Inspect the shoe assembly and replace if excessively worn.

PREVENTIVE MAINTENANCE / CW-7 CIRCLE WELDER

Refer to CW-7 Electrical Component Chart. (Pg. 12)

GMA Wire Feed Control Item #6:

Open control box, use an air hose to blow out dust and dirt. Check all wires for breaks and replace if necessary. Check all electrical connectors and plugs. If an electrical component fails refer to CWO-3332 Wire Feeder Control electrical component chart for replacement parts or return for service.

M-14 Rotation Control Item #15:

Open control box use an air hose to blow out dust and dirt. Check all wires for breaks and replace if necessary. Check all electrical connectors and plugs. If an electrical component fails refer to CWO-6210 Rotation Control electrical component chart for replacement parts or return or service.

LN-7 Wire Feeder Assembly Item #9:

Check brushes for wear. Brushes should be replaced when their length is less than 1/4 inch. Replace strain relief on wire if pulled out of motor housing.

Brush Holder & Support Item #3:

Inspect brush holder. Make sure constant tension is being applied on the brushes. Brushes should move freely within the brush holder. Check brushes for arc build-up. If brushes are pitted they will need replaced. Remove the brushes and sand them to ensure a smooth contact surface. Make sure all fasteners are tight.

Small Brush Retainer Assembly Item #8:

Inspect black brush holders for cracks and replace if needed. Check and make sure all wires are soldered properly to the holders. Replace the brushes when their length is less than 1/2 inch long. Remove the brushes and sand them to ensure a smooth contact surface. Make sure all fasteners are tight.

Terminal Block Item #13:

Inspect the plastic terminal strip and make sure it is not cracked, replace if necessary. Make sure all terminal connections are tight. Make sure all ground wires are connected to the mounting screws of the terminal strip.

EVERY TWELVE MONTHS:

Refer to CW-7 Exploded View Parts List. (Pg. 10, 11)

1-1/2" Bearing With Fasteners Item #26:

Do not grease the bearing, it is greased for life by the manufacturer. If the grease fitting has not been removed and plugged we suggest that you do so now. Earlier models may not have been plugged at time of assembly.

P.M. Motor Assembly Item #15:

Bodine gear motor lubrication. Fill gear motor to oil level indicator with worm gear oil conforming to AGMA#5EP compounded (SAE#90) oil or Bodine lubricant (#L-23). Do not overfill.

LN-7 Wire Feeder Assembly Item #17:

Apply graphite grease to the gear teeth. Inspect the drive roll portion of the assembly, clean as necessary. Do not use solvents on the idle roll because it may wash the lubricant out of the bearings. Do not apply grease to the drive rolls.

Transmission 5:1 Assembly Item #14:

Inspect for excessive wear and tear. Keep the transmission assembly clean and lubricate with Lubriplate #630-AA.

PREVENTIVE MAINTENANCE / CW-7 CIRCLE WELDER

Refer to CW-7 Electrical Component Chart. (Pg. 12)

CW-7 Collector Item #11:

The collector ring should be sanded once a year. If the collector ring is pitted too badly it should be replaced. Inspect all wires coming out of the collector ring for cut or missing insulation. All wires should be fastened to the center shaft with a nylon cable tie. Tighten four set screws if needed.

Weld Cable Inlet 3/0 Item #12:

Ensure that the cable is fastened tightly to the collector ring. Inspect the cable for cut or missing insulation. Make sure the micarta insulation tube on the cable is in good condition. Replace the cable if necessary.

Solenoid Adaptor Kit Item #16:

Inspect for damage. Replace if necessary.

GMA Pigtail Item #5:

Inspect the cable for cuts or missing insulation. Ensure that the elbow connector is not damaged. Ensure that all terminal ends are snug. Replace cable if necessary.

WARRANTY

Limited 3-Year Warranty

Model _____
Serial No. _____
Date Purchased: _____
Where Purchased: _____

For a period ending one (1) year from the date of invoice, Manufacturer warrants that any new machine or part is free from defects in materials and workmanship and Manufacturer agrees to repair or replace at its option, any defective part or machine. HOWEVER, if the invoiced customer registers the Product Warranty by returning the Warranty Registration Card supplied with the product within 90 days of the invoice date, or by registering on-line at www.bugo.com, Manufacturer will extend the warranty period an additional two (2) years which will provide three (3) total years from the date of original invoice to customer. This warranty does not apply to machines which, after Manufacturer's inspection are determined by Manufacturer to have been damaged due to neglect, abuse, overloading, accident or improper usage. All shipping and handling charges will be paid by the customer.

The foregoing express warranty is exclusive and Manufacturer makes no representation or warranty (either express or implied) other than as set forth expressly in the preceding sentence. Specifically, Manufacturer makes no express or implied warranty of merchantability or fitness for any particular purpose with respect to any goods. Manufacturer shall not be subject to any other obligations or liabilities whatsoever with respect to machines or parts furnished by Manufacturer.

Manufacturer shall not in any event be liable to Distributor or any customer for any loss of profits, incidental or consequential damages or special damages of any kind. Distributor's or customer's sole and exclusive remedy against Manufacturer for any breach of warranty, negligence, strict liability or any other claim relating to goods delivered pursuant hereto shall be for repair or replacement (at Manufacturer's option) of the machines or parts affected by such breach.

Distributor's Warranty:

In no event shall Manufacturer be liable to Distributor or to any customer thereof for any warranties, representations or promises, express or implied, extended by Distributor without the advance written consent of Manufacturer, including but not limited to any and all warranties of merchantability or fitness for a particular purpose and all warranties, representations or promises which exceed or are different from the express limited warranty set forth above. Distributor agrees to indemnify and hold Manufacturer harmless from any claim by a customer based upon any express or implied warranty by Distributor which exceeds or differs from Manufacturer's express limited warranty set forth above.

HOW TO OBTAIN SERVICE:

If you think this machine is not operating properly, re-read the instruction manual carefully, then call your Authorized BUG-O dealer/distributor. If they cannot give you the necessary service, write or phone us to tell us exactly what difficulty you have experienced. BE SURE to mention the MODEL and SERIAL numbers.