



CW-5 (CWO-1500-MG) Circle Welder

Features:

- Wire feeder control.
- Wire feeder with one set of drive rolls.
- P.M. motor and speed control for rotation.
- Gun and cable assembly.
- Adaptor kit with 120 VAC solenoid valve.
- 5/8" (16 mm) gas cup.
- Burnback control.
- 50 ft. (15 m) control cable and gas hose.
- Quick disconnects for welding lead.
- Weld switch.
- Cold wire inch switch.
- Wire direction switch.
- Pre and post flow kit.
- Wire reel adaptor for 30 lbs. (14 kg) spools.
- Vertical and horizontal adjustment rack and pinion.
- Rise and fall slide assembly.
- Rise and fall cam with 5" (125 mm) of movement.
- Brushes and collector rings for welding current, rated at 300 amps 100% duty cycle.

Technical Data:

Current Rating:	0-300 amps, 100% duty cycle
Input Voltage:	115 VAC (From Welder)
Wire Sizes:	.035-3/32" (0.8-2.36 mm)
Rise and Fall Cam:	5" (125 mm)
Rotation Speed:	.5-5.9 rpm
Welding Diameter:	1-12" (25-300 mm)
Height:	29" (737 mm)
Net Weight:	160 lbs. (73 kg)

The CW-5 may be used with any constant voltage power source with connections for 115 VAC and weld contactor. The machine may be used for MIG or flux cored process.

Options:

- CWO-1645 Pendulum Type Oscillator
Variable Speed Mechanical
- CWO-3670 Step Adaptor
1/2-4" (13-102 mm) couplings.
- CWO-4530 Carriage with lever.
- CWO-4540 Carriage with winch.
- CWO-4550 Carriage with motorized lift.

Motorized racking is available.

All controls may be removed with operator's pendant.
Water cooling package for water cooled gun is available.

FRONT ELEVATION

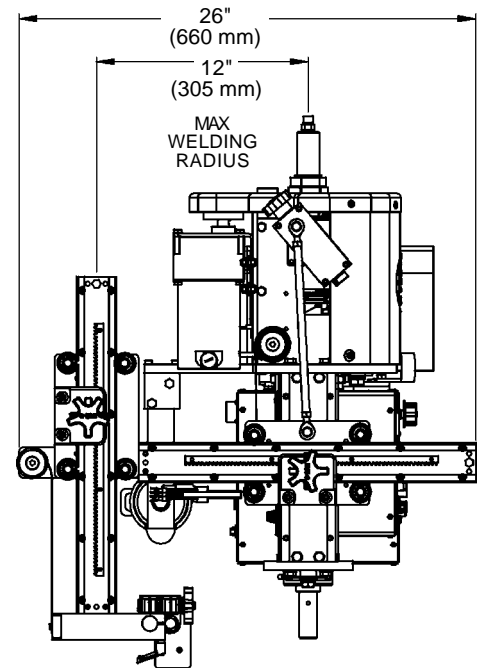

SIDE ELEVATION

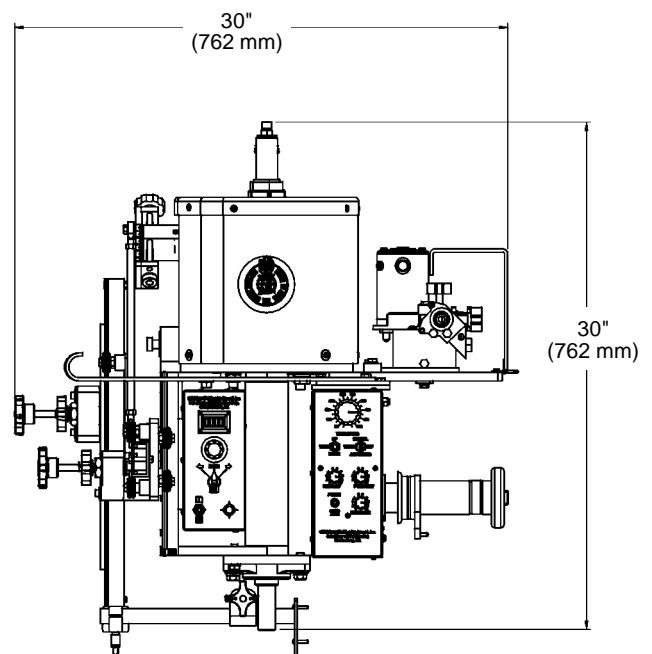



CW-5 (CWE-1500) Programmable Circle Welder

Features:

- Wire feeder control.
- Wire feeder with one set of drive rolls.
- P.M. motor and speed control for rotation with digital readout.
- Gun and cable assembly.
- Adaptor kit with 120 VAC solenoid valve.
- 5/8" (16 mm) gas cup.
- Burnback control.
- 50 ft. (15 m) control cable and gas hose.
- Quick disconnects for welding lead.
- Weld switch.
- Cold wire inch switch.
- Wire direction switch.
- Pre and post flow kit.
- Wire reel adaptor for 30 lbs. (14 kg) spools.
- Vertical and horizontal adjustment rack and pinion.
- Rise and fall slide assembly.
- Rise and fall cam with 5" (125 mm) of movement.
- Brushes and collector rings for welding current, rated at 300 amps 100% duty cycle.
- Emergency stop.
- Overlap.
- Return to start position.

Technical Data:

Current Rating:	0-300 amps, 100% duty cycle
Input Voltage:	115 VAC (From Welder)
Wire Sizes:	.035-3/32" (0.8-2.36 mm)
Rise and Fall Cam:	5" (125 mm)
Rotation Speed:	.5-5.9 rpm
Welding Diameter:	1-12" (25-300 mm)
Height:	29" (737 mm)
Net Weight:	160 lbs. (73 kg)

The CW-5 may be used with any constant voltage power source with connections for 115 VAC and weld contactor. The machine may be used for MIG or flux cored process.

Options:

CWO-1645	Pendulum Type Oscillator Variable Speed Mechanical
CWO-3670	Step Adaptor 1/2-4" (13-102 mm) couplings.
CWO-4530	Carriage with lever.
CWO-4540	Carriage with winch.
CWO-4550	Carriage with motorized lift.

Motorized racking is available.
All controls may be remoted with operator's pendant.
Water cooling package for water cooled gun is available.

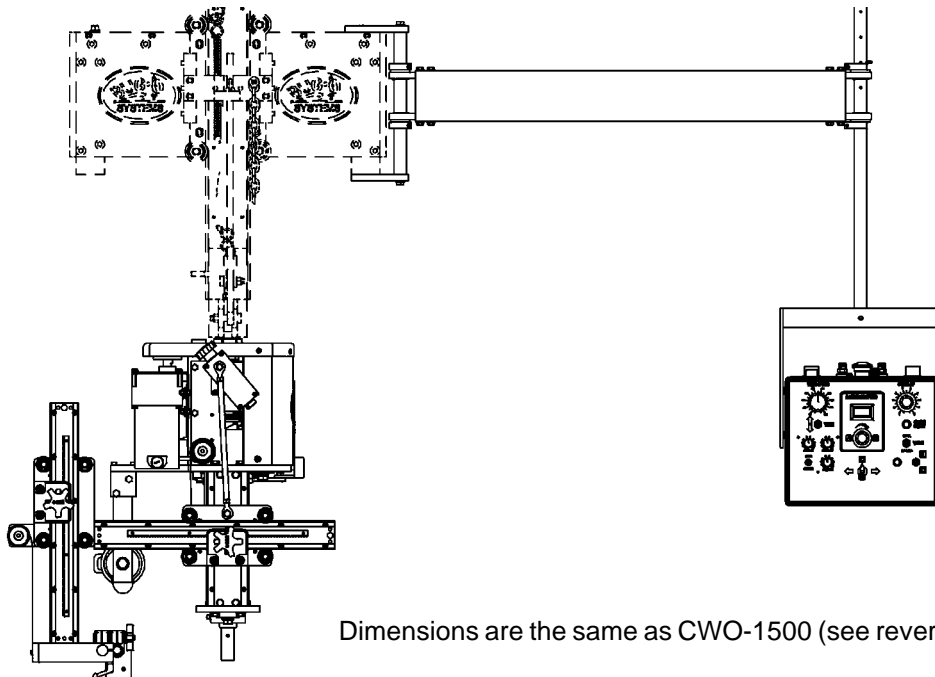

Dimensions are the same as CWO-1500 (see reverse side).